



TRANE®

*Cooling and Heating
Systems and Services*

Indoor liquid chiller with integrated hydraulic module

**Water-cooled: CGWN 205 – 206 – 207
– 208 – 209 – 210 – 211 – 212 – 213
– 214 – 215**

**Condenserless: CCUN 205 – 206 – 207
– 208 – 209 – 210 – 211 – 212 – 213
– 214 – 215**

AquaStream²



CG-PRC014-E4



Contents

Introduction	4
Features and benefits	5
Options description	9
Applications consideration	10
Control	15
Selection Procedures	21
Performances	22
General data	24
Hydraulic data	31
Sound performances	35
Units schematics	37
Mechanical Specifications	44

Introduction

The new Indoor AquaStream²® chillers range equipped with Scroll compressors combines the latest technologies available to offer an optimum answer for today's air-conditioning and process cooling applications:

- Scroll compressor technology, with high performance, limited maintenance and longer life time design
- Latest generation of Trane controls, with user friendly graphical interface and integral auto-adaptive to guarantee maximum dependability
- High efficiency heat exchangers, allowing significant savings on operating cost
- Integrated hydraulic packages, to shorten installation and commissioning time.

Features and benefits

Industry leading performance and flexibility for design engineers

The next generation: designed for You

The third generation of the successful indoor Scroll compressor product range has several benefits over the previous design. Your suggestions led to the improvements we've incorporated, including:

- Higher full-load energy efficiency for lower operating and life-cycle costs
- CH530 controls, with touch-screen display and LonTalk® capability
- Less sensitivity to condenser-water temperatures, alleviating concerns based on start-up temperatures
- Lighter weight for easier and less expensive handling and installation.

Applications: Operation and control advantages for most application

The Scroll compressor technology, with fewer moving parts, less rotating mass and less internal friction, associated with CH530 and Adaptive Controls™, allow the Indoor AquaStream²® range to be used in a wide variety of applications including:

- Comfort cooling: designed for reliability, energy efficiency, and system-design optimisation, whether the heat is rejected via an open cooling tower or a closed loop device (dry-cooler)
- Industrial process cooling: reliable operation with tight control of temperatures
- Ice/thermal storage
- Heat recovery
- Low-temperature process cooling.

System design and control: Greater application flexibility for increased savings

First-cost and operating cost minimising system-design concepts are catching on as their validity is proven through applications.

These designs can provide lower equipment costs and lower operating costs than those possible with the traditional design methods and past chiller technologies.

The concepts of the Indoor AquaStream²® range include:

- Heat exchangers with reduced water pressure drops and wider water flow/delta capability
- Thermal storage capability
- Variable primary (evaporator) chilled-water flow capability
- Series evaporator and/or condenser arrangements

The Indoor AquaStream²® range is designed for a wide range of applications and is especially suited for the dynamics of these system saving job designs. The dynamic benefits include:

- Efficient lift capability
- Tight temperature control.

CH530 controls mean that the CGWN/CCUN series chillers can maintain tight leaving-water temperature control in almost any application. These benefits fit especially well with the system design savings ideas listed above. As the compressor reaches the operating temperatures for the application, the controls, make sure you have total temperature control, even with chilled-water flow and/or load changes.

Features and benefits

Sound: Lower sound levels through compressor and chiller design

Trane has a proven track record of continuously improving the sound levels of water chillers. With the Indoor AquaStream²® range, Trane has designed a fully hermetic cabinet design which minimises sound radiation in the neighbourhood of the unit. The space around the chiller can be utilised without requirement of additional sound insulation. The CCUN + outdoor condensing module can be an interesting alternative to an outdoor chiller: only the sound produced by the condenser fans can be perceived in the surrounding of the installation, the sound of compressor is attenuated by the building structure.

Minimised job time for contractors through design and testing

Ease of installation

- Footprint: Central to the design of any project is the operating envelope of the chiller. With this in mind, Trane builds the chillers to make the most efficient use of the available installation space. The compact Indoor AquaStream²® range chiller is an excellent choice for any retrofit or replacement job. It is smaller than most chillers it might replace, and easier to fit into existing buildings. All units fit through a standard single door.
- Weight: Furthermore, the decreased weight reduces the requirements for lifting, rigging, and installation. Installation time and effort are reduced when dealing with a significantly smaller and lighter unit.
- Commissioning: Water cooled units (CGWN) come from the factory fully charged with refrigerant and oil, condenserless version (CCUN) with holding charge. Extensive factory testing helps ensure trouble-free start-up, resulting in lower installation costs and faster job completion.

Everything is in the box

Thanks to built-in components, installation is easy and you will make considerable savings using any available space in the technical room.

Only a main power supply and water connections are necessary, the main hydraulic components can be supplied in the "box".

The Indoor AquaStream²® integrated hydraulic can be supplied with the following components:

- Evaporator pump
- Evaporator strainer
- Expansion tank on cooling loop
- Valves
- Flow switch
- Pressure gauge
- Relief valve
- Condenser pump
- Condenser strainer.

The Integrated comfort system

The water-cooled AquaStream²® chiller, with the CH530, makes a powerful combination with the Trane Tracer Summit Building Management System to become part of a Trane Integrated Comfort system (ICS). An Integrated Comfort system is a building comfort system composed of Trane HVAC equipment, integral unit controllers, and building management. It is all designed and commissioned with Trane application expertise to provide comfort, efficiency, and reliability, as well as single-source warranty and service. Whether you are replacing a chiller or adding one to any centrally controlled plant, the Tracer CH530 chiller controller offers a wide range of interface options. Its ability to communicate with other systems using industry-standard control signals allows you to upgrade the control of your chiller plant regardless of your current control system.

Features and benefits

Single-source responsibility

A wide range of products designed for complete compatibility are available with the Indoor AquaStream²[®] scroll chillers. Your entire building comfort system can be completed using components from Trane.

The added value of applications expertise

You get a quality chiller, properly selected and applied in a properly designed system. That means a comfort system that works, the first time!

Reduced total life cycle operating cost for building owner.

Energy efficiency: Reduced annual operating expenses

The Indoor AquaStream²[®] chiller design has been optimized in order to achieve record efficiency levels. With the CH530 chiller control module, control over the chilled-water temperature is increased, simultaneously reducing annual operating costs. Indoor AquaStream²[®] chillers offer superior full-load performance and optimised part-load performance.

Reduced maintenance: Less time and money every year

The only recommended maintenance for an Indoor AquaStream²[®] chiller is an annual oil analysis. The hermetic design allows the compressor to be driven by a zero-maintenance motor. Strainers upstream the evaporator and condenser enhance the lifetime of heat exchangers. The Adaptive Control[™] microprocessor also helps reduce unnecessary maintenance by monitoring, protecting, and taking corrective action so that the chiller stays on-line when you need it the most. Service calls for nuisance trip-outs are virtually eliminated.

Reliability

Trane has designed the Indoor AquaStream²[®] chiller range to be a leader in reliability for all applications:

- Simple design with 64 percent fewer parts than equal capacity reciprocating compressor.
- Advanced microelectronics protect both compressor and motor from typical electrical fault conditions.
- Scroll compressors have less than a third the torque variations of a reciprocating compressor.
- Years of laboratory testing have optimised compressor and chiller systems reliability.
- Water-cooled scroll chillers are factory tested.

Comfort cooling: designed for reliability, energy efficiency, and system design optimisation

Most comfort-cooling applications consider reliability and energy efficiency above all else in the design requirements. With proven reliability and high chiller efficiency, the Indoor AquaStream²[®] chillers are perfectly suited for these applications.

Industrial process cooling / Low temperature process: Reliable operation with tight control of temperatures

The Trane Indoor AquaStream²[®] chillers have the proven reliability required to keep the process running, eliminating concerns for chiller and resulting process downtime. The chiller matches system requirements and rapidly adjusts to match the changes seen by most processes.

Features and benefits

Ice / thermal storage

The Trane Indoor AquaStream²® chillers can be used in partial or full thermal-storage applications because of their excellent compressor lift (operating temperature range) capability. High reliability and low maintenance means thermal storage applications are possible without a full-time operation/maintenance staff, and Trane Integrated Comfort System Controls can notify a computer or pager of any system issues.

Heat recovery

The Trane Indoor AquaStream²® chillers compressor lift capabilities also play well in heat recovery, or just high-temperature condenser applications. Building energy saving initiatives such as using condenser water for reheat (dehumidification), preheating boiler water, and providing domestic hot water are compatible with its temperature capabilities.

Easy serviceability

Trane Indoor AquaStream²® chillers are designed with service personnel in mind. All major components are replaceable without complete unit disassembly. Plus, CH530 provides diagnostic capability to aid service personnel in analysing problems. Therefore, in case a problem does occur, the chiller can be up and running in a shorter period of time.

Options description

Evaporator hydraulic module

Versions available:

- No hydraulic control
- With pump contactors to control a remote pump (single or dual)
- With pump integrated hydraulic module, single or dual pump, low or high pressure head

Hydraulic module contents:

- Single or dual pump
- Expansion vessel
- Water pressure relief valve set to 4 bar
- Water strainer easily removable to allow quick cleaning.
- Drainage valve
- Pressure ports for gauge connection
- Water pressure gauge
- Condensate collection and drainage (below pump)
- Pump winter freeze protection down to -18°C (the pump is activated under an ambient temperature setting)

Condenser hydraulic module

Versions available:

- No hydraulic control
- With pump contactors to control a remote pump (single or dual)
- With pump integrated hydraulic module:
 - 180 kW - 350 kW: 2 single pumps in parallel to adjust condenser waterflow as a function of unit capacity, low or high pressure head
 - 350 kW - 500 kW: Dual pump, low or high pressure head.
- With pump integrated hydraulic module and variable speed drives:
 - 180 kW - 350 kW: same pumps with separate variable speed drive
 - 350 kW - 500 kW: specific pump with integrated variable speed drive

Hydraulic module contents:

- Two pumps in parallel : 180 kW - 350 kW (Variable speed drive available as option)
- One dual pump: 350 kW - 500 kW (Variable speed drive available as option)
- Water strainer easily removable to allow quick cleaning.
- Drainage valve
- Pressure ports for gauge connection
- Pump winter freeze protection down to -18°C (the pump is activated under an ambient temperature setting)

Hot water control

This option allows the control of the unit capacity based on the leaving condenser-water temperature to permit heat recovery.

Phase protection device

Inhibits operation of chiller in case of phase reversal

Soft starter

To reduce starting current during compressor start

Setpoint and temperature offset and display card

Allows to offset chilled water setpoint temperature based on either outside air, chilled water return or zone temperature and provides inlet/outlet condenser water temperature information.

High Efficiency Option (Only for 180-350 kW range)

This option provides oversized heat exchangers to allow the unit to be more energy efficient.

Ice Making

The unit controls are factory set to handle ice making for thermal storage applications.

Communication Interface

Permits bi-directional communication to the Trane Integrated Comfort™ system and provides the LonMark® chiller profile input/outputs for use with a generic BAS (Building Automation System)

Low Noise Version

The unit is equipped with a compressor sound attenuating enclosure.

Pressure Gauges

A set of two pressure gauges per refrigerant circuit, one for low pressure and one for high pressure.

Flange Connection Kit

Provides a kit that includes a set of two pipe stubs and flange couplings.

Applications consideration

Optimum performance of CGWN and CCUN units will be achieved only if proper application guidelines are followed.

Where the application varies from the guidelines presented, it should be reviewed with your local Trane sales engineer.

Unit sizing

Unit capacities are listed in the "Performance Data" section. Intentionally oversizing a unit to assure adequate capacity is not recommended. Erratic system operation and excessive compressor cycling are often a direct result of an oversized unit. In addition, an oversized unit is usually more expensive to purchase, install and operate. If oversizing is desired, consider using two units.

Foundations

A special foundation is not required, provided the floor is flat, level and strong enough to support the unit's weight (see "General data" tables).

Sound insulation

4 or 6 vibration isolators are supplied as standard. They will be inserted between the floor and the unit to attenuate vibration. An acoustics engineer should always be consulted when noise is a critical factor.

Water drain

Ensure that near the unit is a large enough drain to evacuate the water when from the system emptying the unit for shutdown or repair.

Water connection

Units are supplied as standard with 3" male Victaulic connections. Should flange connection be used, use the adapted connection kit available. It is not allowed to weld on Victaulic connections.

Minimum water volume

The minimum recommended water volume depends on the type of application.

If necessary, provide a buffer tank. The control and safety devices are only certain to operate correctly if the system's water volume is sufficient.

Table 1 - Minimum installation water volume recommended

	Confort Application			Process cooling Application		
	2°C Dead band (1)	3°C Dead band (2)	4°C Dead band (3)	2°C Dead band (1)	3°C Dead band (2)	4°C Dead band (3)
CGWN - CCUN 205	660 l	440 l	330 l	1160 l	730 l	530 l
CGWN - CCUN 206	670 l	450 l	340 l	1160 l	740 l	540 l
CGWN - CCUN 207	650 l	440 l	330 l	1100 l	710 l	520 l
CGWN - CCUN 208	880 l	580 l	440 l	1520 l	960 l	710 l
CGWN - CCUN 209	1060 l	700 l	530 l	1860 l	1170 l	860 l
CGWN - CCUN 210	1080 l	720 l	540 l	1870 l	1190 l	870 l
CGWN - CCUN 211	1260 l	840 l	630 l	2220 l	1400 l	1020 l
CGWN - CCUN 212	1260 l	840 l	630 l	2170 l	1380 l	1010 l
CGWN - CCUN 213	1050 l	700 l	530 l	1760 l	1130 l	830 l
CGWN - CCUN 214	1270 l	850 l	640 l	2150 l	1370 l	1010 l
CGWN - CCUN 215	1240 l	820 l	620 l	2060 l	1330 l	980 l

Notes

- (1) Minimum water loop volume in order to obtain maximum +/- 1°C chilled water temperature fluctuation vs. Chilled water set-point
 - (2) Minimum water loop volume in order to obtain maximum +/- 1.5°C chilled water temperature fluctuation vs. Chilled water set-point
 - (3) Minimum water loop volume in order to obtain maximum +/- 2°C chilled water temperature fluctuation vs. Chilled water set-point
- This table is estimated with
- Condenser : Water 30°/35°C
 - Evaporator : Water 12°/7°C

Applications consideration

Water treatment

The use of untreated or improperly treated water in chillers may result in scaling, erosion, corrosion or algae. It is recommended that the services of a qualified water-treatment specialist be obtained to determine what water treatment, if any, is advisable. Trane assumes no responsibility for the results of untreated, or improperly treated water.

Flow rate limits

The minimum and maximum flow rates are indicated in the "Hydraulic data" charts section. Too low a flow rate may cause freezing of the evaporator. Too high a flow rate may cause erosion of the evaporator and very substantial pressure losses.

Operating Range

Figure 1 - CGWN operating limits (180 kW-350 kW)

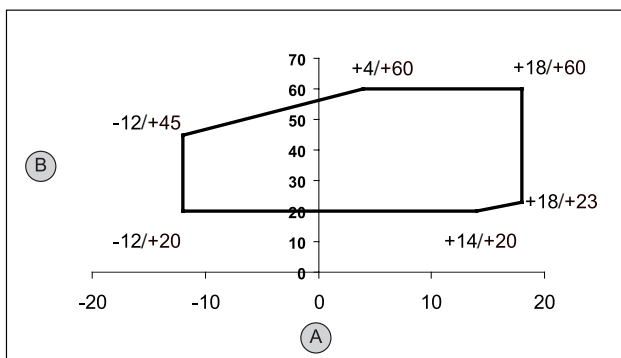

A = Evaporator leaving water temperature (°C)
B = Saturated condensing temperature (°C)

Figure 2 - CGWN operating limits (350 kW-500 kW)

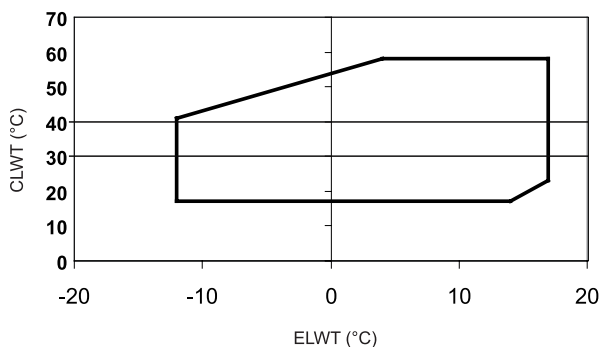

CLWT: Condenser Leaving Water Temperature
ELWT: Evaporator Leaving Water Temperature

Figure 3 - CCUN operating limits (180 kW-350 kW)

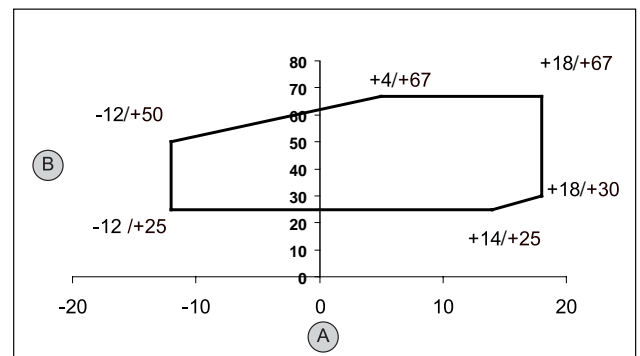

A = Evaporator leaving water temperature (°C)
B = Saturated condensing temperature (°C)

Figure 4 - CCUN operating limits (350 kW-500 kW)

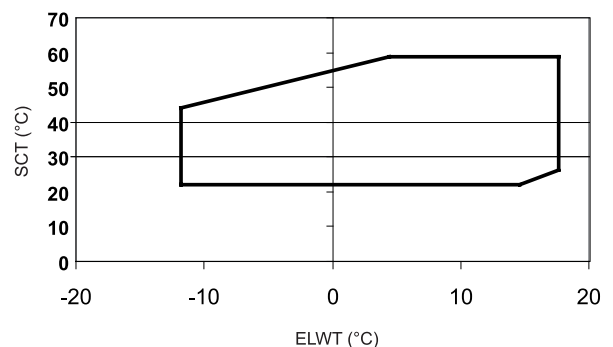

SCT: Saturated Condensing temperature
ELWT: Evaporator Leaving Water Temperature

Applications consideration

Split systems piping recommendations

Maximum distances and refrigerant line diameters between units must be checked according to the configuration and system operating conditions (Chilled water temperature and subcooling). Tables 2 to 4 provide the maximum acceptable height according to subcooling available and recommended diameters for discharge liquid lines.

Figure 5 - Installation configuration - CCUN and remote condensing unit at the same level

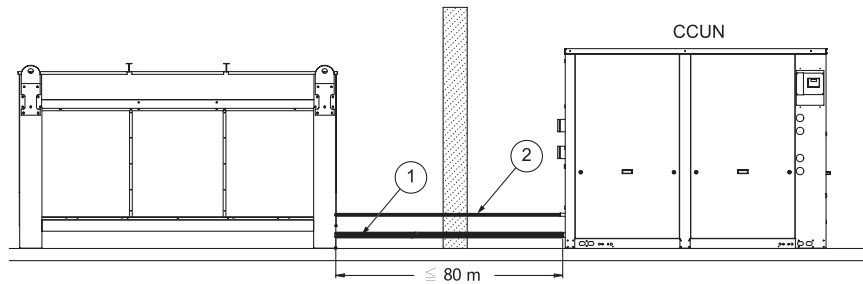

- 1: Discharge line
- 2: Liquid line

Figure 6 - Installation configuration - CCUN below remote condensing unit

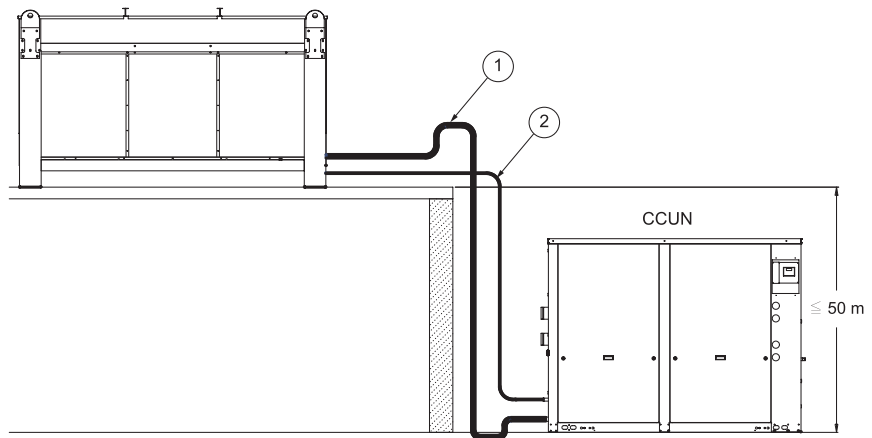

- 1: Discharge line
- 2: Liquid line

Applications consideration

Figure 7 - Installation configuration - CCUN above remote condensing unit

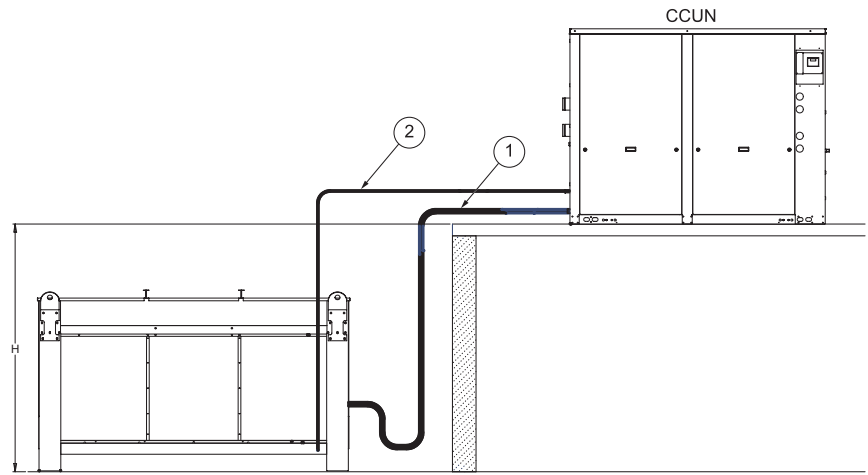

- 1: Discharge line
- 2: Liquid line

Table 2 - Maximum elevation (H) of CCUN above remote condensing unit

Subcooling °C	Condensing dew temperature °C			
	20°C	35°C	50°C	65°C
4°C	4 m	6 m	8 m	10 m
6°C	8 m	12 m	16 m	20 m
8°C	12 m	17 m	23 m	30 m
10°C	16 m	23 m	30 m	40 m
12°C	20 m	28 m	38 m	49 m

Table 3 - Recommended discharge line diameters for horizontal risers (Circuit 1)

		Required discharge pipe diameter - Circuit 1													
Unit size		-12	-10	-8	-6	-4	-2	0	2	4	6	8	10	12	14
CCUN	205			7/8"						1 1/8"					1 3/8"
CCUN	206		7/8"					1 1/8"						1 3/8"	
CCUN	207		7/8"					1 1/8"						1 3/8"	
CCUN	208			1 1/8"						1 3/8"					1 5/8"
CCUN	209			1 1/8"						1 3/8"					1 5/8"
CCUN	210			1 1/8"						1 3/8"					1 5/8"
CCUN	211			1 1/8"						1 3/8"					1 5/8"
CCUN	212			1 5/8"								2 1/8"			
CCUN	213			1 5/8"								2 1/8"			
CCUN	214		1 5/8"						2 1/8"					2 5/8"	
CCUN	215		1 5/8"						2 1/8"					2 5/8"	

Applications consideration

Table 4 - Recommended discharge line diameters for horizontal risers (Circuit 2)

		Required discharge pipe diameter - Circuit 2													
	Unit size	-12	-10	-8	-6	-4	-2	0	2	4	6	8	10	12	14
CCUN	205			7/8"							1 1/8"				1 3/8"
CCUN	206		7/8"					1 1/8"						1 3/8"	
CCUN	207		7/8"					1 1/8"						1 3/8"	
CCUN	208			1 1/8"							1 3/8"				1 5/8"
CCUN	209			1 1/8"							1 3/8"				1 5/8"
CCUN	210			1 1/8"						1 3/8"					1 5/8"
CCUN	211			1 1/8"						1 3/8"					1 5/8"
CCUN	212		1 3/8"				1 5/8"							2 1/8"	
CCUN	213			1 5/8"							2 1/8"				
CCUN	214			1 5/8"							2 1/8"				
CCUN	215		1 5/8"					2 1/8"						2 5/8"	

Table 5 - Recommended liquid line diameters for vertical or horizontal risers (Circuit 1)

		Required liquid line pipe diameter - Circuit 1													
	Unit size	-12	-10	-8	-6	-4	-2	0	2	4	6	8	10	12	14
CCUN	205			5/8"							7/8"				1 1/8"
CCUN	206		5/8"			7/8"							1 1/8"		
CCUN	207		5/8"			7/8"							1 1/8"		
CCUN	208			7/8"						1 1/8"					1 3/8"
CCUN	209			7/8"						1 1/8"					1 3/8"
CCUN	210		7/8"			1 1/8"							1 3/8"		
CCUN	211		7/8"			1 1/8"							1 3/8"		
CCUN	212			1 1/8"						1 3/8"					1 5/8"
CCUN	213			1 1/8"						1 3/8"					1 5/8"
CCUN	214			1 1/8"				1 3/8"						1 5/8"	
CCUN	215			1 1/8"				1 3/8"						1 5/8"	

Table 6 - Recommended liquid line diameters for vertical or horizontal risers (Circuit 2)

		Required liquid pipe diameter - Circuit 2													
	Unit size	-12	-10	-8	-6	-4	-2	0	2	4	6	8	10	12	14
CCUN	205			5/8"							7/8"				1 1/8"
CCUN	206		5/8"			7/8"							1 1/8"		
CCUN	207		5/8"			7/8"							1 1/8"		
CCUN	208			7/8"						1 1/8"					1 3/8"
CCUN	209			7/8"						1 1/8"					1 3/8"
CCUN	210		7/8"			1 1/8"							1 3/8"		
CCUN	211		7/8"			1 1/8"							1 3/8"		
CCUN	212			1 1/8"							1 3/8"				
CCUN	213			1 1/8"						1 3/8"					1 5/8"
CCUN	214			1 1/8"						1 3/8"					1 5/8"
CCUN	215		1 1/8"					1 3/8"						1 5/8"	

Control

Safety Controls

A centralized microcomputer offers a higher level of machine protection. Because the safety controls are smarter, they limit compressor operation in order to avoid compressor or evaporator failures, thereby minimizing nuisance shutdowns. Tracer™ Chiller Controls directly senses the control variables that govern the operation of the chiller: evaporator pressure, condenser pressure. When any one of these variables approaches a limit condition at which the unit may be damaged or shut down on a safety, Tracer Chiller Controls takes corrective action to avoid shutdown and keep the chiller operating. It does this through combined actions of compressor staging and pump staging. It has also the capability to control the remote condenser fan staging for condenserless unit (CCUN). Tracer Chiller Controls optimizes total chiller power consumption during normal operating conditions. During abnormal operating conditions, the microprocessor will continue to optimize chiller performance by taking the corrective action necessary to avoid shutdown. This keeps cooling capacity available until the problem can be solved. Whenever possible, the chiller is allowed to perform its function: make chilled water. In addition, microcomputer controls allow for more types of protection, like winter freeze protection; the safety controls help keep the building or process running and out of trouble.

Stand-alone controls

Interfacing to stand-alone units is very simple: only a remote auto/stop for scheduling is required for unit operation. Signals from the chilled-water pump contactor auxiliary, or a flow switch, are wired to the chilled-water flow interlock. Signals from a time clock or some other remote device are wired to the external auto/stop input.

Tracer™ Chiller Control human interfaces



Control

Standard Features External Auto/Stop

A job-site-provided contact closure will turn the unit on and off.

Chilled Waterflow Interlock

Unit is equipped with a water flow control which allows unit operation if a load exists. This feature will allow the unit to run in conjunction with the pump system.

External Interlock

A job-site-provided contact opening wired to this input will turn the unit off and require a manual reset of the unit microcomputer. This closure is typically triggered by a job-site-provided system such as a fire alarm.

Chilled Water Pump Control

Unit controller manage operation of the optional chilled and hot water pump of the chiller. When hydraulic modules are not mounted, unit controls provide an output to control the chilled-water pump(s). One contact closure to the chiller is all that is required to initiate the chilled-water system. Chilled water pump control by the chiller is a requirement for all Indoor AquaStream² chillers.

Seven day scheduling

This function provides a means of scheduling the chiller operation on a daily basis. Thus simple chiller scheduling can be performed without the need for a building automation system.

Alarm Indication Contacts

Four factory-installed contacts with the following preset default assignments:

- Alarm
- Chiller running
- Maximum capacity
- Chiller limit.

Additional Features that May Be Added (require some optional factory-installed hardware)

- Ice-making card
- Tracer communication card
- Chilled water and remote current limit set point card (note: all wiring outside the unit is supplied by the contractor).

Easy Interface to a Generic Building Management System

Controlling the Indoor AquaStream² chillers with building management systems is state-of-the-art, yet simple with either:

- the LonTalk Communications Interface for Chillers (LCI-C)
- or Generic Building Management System Hardwire Points.

Simple Interface with Other Control Systems

Microcomputer controls afford simple interface with other control systems, such as time clocks, building automation systems, and ice storage systems. This means you have the flexibility to meet job requirements while not having to learn a complicated control system. This setup has the same standard features as a stand-alone water chiller, with the possibility of having additional optional features.

Control

What are LonTalk, Echelon, and LonMark?

LonTalk is a communications protocol developed by the Echelon Corporation. The LonMark association develops control profiles using the LonTalk communication protocol. LonTalk is a unit level communications protocol, unlike BACNet used at the system level.

LonTalk Communications Interface for Chillers (LCI-C)

LonTalk Communications Interface for Chillers (LCI-C) provides a generic automation system with the LonMark chiller profile inputs/outputs. The inputs/outputs include both mandatory and optional network variables.

Note: LonMark network variable names are in parentheses when different from chiller naming convention.

Chiller Inputs:

- Chiller Enable/Disable
- Chilled Liquid Setpoint (Cool or hot Setpoint)
- Ice Making (Chiller Mode)

Chiller Enable/Disable

Allows the chiller to be started or stopped depending on if certain operating conditions are met.

Chilled Liquid Setpoint

Allows the the external setting independent of the front panel setpoint to adjust the leaving water temperature setpoint.

Hot Liquid Setpoint

Allows the external setting independent of the front panel setpoint to adjust the leaving water temperature setpoint from the condenser.

Ice Making

Provides interface with ice making control systems.

Chiller Outputs:

- On/Off Active Setpoint
- Leaving Chilled Water Temperature
- Entering Chilled Water Temperature
 - Leaving Hot Water Temperature
 - Entering Hot Water Temperature
- Alarm Descriptor
- Chiller Status

Control

On/Off

Indicates the current state of the chiller

Active Setpoint

Indicates the current value of the leaving water temperature setpoint

Leaving Chilled Water Temperature

Provides the current leaving water temperature

Entering Chilled Water Temperature

Provides the current entering water temperature.

Leaving Hot Water Temperature (Optional feature)

Provides the current leaving water temperature from the condenser.

Entering Hot Water Temperature (Optional feature)

Provides the current entering water temperature from the condenser.

Alarm Descriptor

Provides alarm messages based on predetermined criteria.

Chiller Status

Indicates the running modes and states of the chiller, i.e. Running in alarm mode, chiller enabled, chiller being locally controlled, etc.

Generic Building Management System Hardware Points

GBAS may be achieved via hardware input/output as well. The input/outputs are as follows:

Chiller hardwire inputs include:

- Chiller enable/disable
- Circuit enable/disable
- External chilled water setpoint - (Optional feature)
- Ice making enable – (Optional feature)

External Chilled Water Setpoint - (Optional feature)

Allows the external setting independent of the front panel setpoint by one of two means:

- a) 2-10 VDC input, or
- b) 4-20 mA input

Chiller hardwire outputs include:

- Compressor running indication
- Alarm indication (Ckt 1/Ckt 2)
- Maximum capacity
- Ice making status

Alarm Indication Contacts

The unit provides three single-pole/double-throw contact closures to indicate:

- a) Compressor on/off status
- b) Compressor running at maximum capacity
- c) Failure has occurred (Ckt 1/Ckt 2)

These contact closures may be used to trigger job site supplied alarm lights or alarm bells.

Ice Making Control - (Optional feature)

Provides interface with ice making control systems.

Control

Tracer Summit™ Controls — Interface with the Trane Integrated Comfort System (ICS)

Trane Chiller Plant Control

The Tracer Chiller Plant Manager building management system provides building automation and energy management functions through stand-alone control. The Chiller Plant Control is capable of monitoring and controlling your entire chiller plant system.

Application software available:

- Time-of-day scheduling
- Chiller sequencing
- Process control language
- Boolean processing
- Zone control
- Reports and logs
- Custom messages
- Run time and maintenance
- Trend log
- PID control loops

And of course, the Trane Chiller Plant Control can be used on a stand-alone basis or tied into a complete building automation system. When the water-cooled chiller is used in conjunction with a Trane Tracer Summit™ system, the unit can be monitored and controlled from a remote location. The water-cooled chiller can be controlled to fit into the overall building automation strategy by using time-of-day scheduling, timed override, demand limiting, and chiller sequencing. A building owner can completely monitor the water-cooled chiller from the Tracer system, since all of the monitoring information indicated on the microcomputer can be read on the unit controllers Tracer system display. In addition, all the powerful diagnostic information can be read back at the Tracer system. Best of all, this powerful capability comes over a single twisted pair of wires!

Water-Cooled chillers can interface with many different external control systems, from simple stand-alone units to ice-making systems. Each unit requires a single-source, three-phase power supply.

A single twisted pair of wires tied directly between the Indoor AquaStream² chillers and a Tracer Summit™ system provides control, monitoring, and diagnostic capabilities. Control functions include auto/stop, adjustment of leaving-water-temperature set point and control of ice-making mode. The Tracer system reads monitoring information such as entering- and leaving-evaporator-water temperatures and entering- and leaving-condenser-water temperatures and outdoor air temperature. Over 60 individual diagnostic codes can be read by the Tracer system. In addition, the Tracer system can provide sequencing control for up to 25 units on the same chilled-water loop. Pump sequencing control can be provided from the Tracer system. Tracer ICS is not available in conjunction with the external set point capability.

Control

Required Options

Tracer Interface

Additional Options that May Be Used

Ice-Making Control

External Trane Devices Required

Tracer Summit™, Tracer 100 System or Tracer Chiller Plant Control

Ice-Making Systems Controls

An ice-making option may be ordered with the water-cooled chiller. The unit will have two operating modes, ice making and normal daytime cooling. In the ice making mode, the water-cooled chiller will operate at full compressor capacity until the return chilled-fluid temperature entering the evaporator meets the ice making set point. Two input signals are required to the water-cooled chiller for the ice-making option. The first is an auto/stop signal for scheduling, and the second is required to switch the unit between the ice-making mode and normal daytime operation. The signals are provided by a remote job site building-automation device such as a time clock or a manual switch. In addition, the signals may be provided over the twisted wire pair from a Tracer™ system, or a LonTalk Communication Interface but will require the communication boards provided with the Ice Making Control Option.

Additional Options That May Be Used

- Failure Indication Contacts Communications Interface (For Tracer Systems)
- Chilled-Water Temperature Reset

Selection Procedures

The performance examples, on the following pages provide performance information at various capacities for the most common conditions.

The stated cooling capacities are based on:

	Evaporator Δt (°C)	Condenser Δt (°C)	Fouling factor (m ² /K/kW)
CGWN Water cooled chillers	5	5	0.0044
CCUN Condenserless chillers	5	-	0.0044
CCUN + remote condensing unit			
Split system	5	-	0.0044

The capacity ratings are applicable to a temperature drop within 4 to 8°C except as limited by the minimum or maximum water-flow rates as indicated by the heat exchanger's hydraulic resistance tables. If a different fouling factor is used, the unit capacity will vary. For conditions that are not directly tabulated, direct interpolation may be used. Extrapolation is not permitted.

Watercooled units: CGWN

To determine the cooling capacity and the power input, the following information is needed:

- the required cooling capacity (Cap.)
- the evaporator leaving water temperature (ELWT)
- the condenser leaving water temperature (CLWT)

Unit power input (P.I.), heat rejected by condenser (RH), evaporator and condenser waterflow rates (respectively EWFR and CWFR) and associated pressure drops (respectively EWPD and CWPDP) are given in the table.

Selection example:

Cooling capacity required (Cap):
180 kW

Evaporator leaving water temperature (ELWT): 7°C

Condenser leaving water temperature (CLWT): 35°C

By using the selection table it can be determined that the CGWN 205 Standard gives a cooling capacity (cap) of 182.5 kW and a power input (P.I.) of 42.5 kW and condenser rejected heat (RH) is 224.19 kW.

Evaporator water flow rate (EWFR) is 8.71 l/s and associated pressure drop (EWPD) is 57 kPa

Condenser water flow rate (CWFR) is 10.70 l/s and associated pressure drop (CWPDP) is 59 kPa

Performances

Table 7 - Correction factors to apply when glycol is used in water loops

Fluid Type	Glycol Concentration		Performance		Evaporator		Condenser	
	Evaporator	Condenser	F-CC	F-PI	F-FLEVP	F-PDEVVP	F-FLCDS	F-PDCDS
Water only	0%	0%	1.00	1.00	1.00	1.00	1.00	1.00
	10%	0%	0.99	1.00	1.02	1.02	1.00	1.00
	20%	0%	0.98	1.00	1.05	1.06	1.00	1.00
	30%	0%	0.97	1.00	1.10	1.10	1.00	1.00
Ethylene Glycol	0%	10%	1.00	1.00	1.00	1.00	1.02	1.05
	0%	20%	1.00	1.01	1.00	1.00	1.04	1.09
	0%	30%	1.00	1.02	1.00	1.00	1.08	1.14
	10%	0%	0.99	1.00	1.01	1.05	1.00	1.01
	20%	0%	0.97	1.00	1.03	1.10	1.00	1.00
	30%	0%	0.96	1.00	1.05	1.17	1.00	1.01
Mono-Propylene Glycol	0%	10%	1.00	1.01	1.00	1.00	1.01	1.06
	0%	20%	1.00	1.01	1.00	1.00	1.02	1.13
	0%	30%	0.99	1.02	1.00	1.00	1.05	1.21

The correction factors found in Table 5 can be applied as follows:

- 1) **Cooling capacity** with glycol [kW] = **F-CC** x Cooling capacity water [kW] (found in tables 6 to 13)
- 2) **Power Input** with glycol [kW] = **F-PI** x Power Input water [kW] (found in tables 6 to 13)
- 3) **Water Flow Evaporator** with glycol [Litres/sec] = **F-FLEVP** x Cooling capacity with glycol [kW] x 0.239 x (1 / Delta T Evaporator [°C])
- 4) **Water Pressure drop Evaporator** with glycol [kPa] = **F-PDEVVP** x Water Pressure drop Evaporator water [kPa] (found in figures 6 and 7)

CGWN Only:

- 5) **Water Flow Condenser** with glycol [Litres/sec] = **F-FLCDS** x (Cooling capacity with glycol [kW] + Power input with glycol [kW]) x 0.239 x (1 / Delta T Condenser [°C])
- 6) **Water Pressure drop Condenser** with glycol [kPa] = **F-PDCDS** x Water Pressure drop Condenser water [kPa] (found in figures 8 and 9)

In case of application with negative temperature at the evaporator, combination of simultaneous usage of glycol both in evaporator and condenser, or usage of another type of fluid: please contact your local Trane sales representative.

Performances

Table 8 - European Seasonal Energy Efficiency Ratio (ESEER) - CGWN Standard

Model	ESEER	A 100% load EER	B 75% load EER	C 50% load EER	D 25% load EER
CGWN 205	5.96	4.29	5.23	6.36	6.50
CGWN 206	6.04	4.32	5.17	6.46	6.77
CGWN 207	6.06	4.36	5.30	6.50	6.60
CGWN 208	6.28	4.60	5.48	6.45	7.33
CGWN 209	5.81	4.45	5.14	6.11	6.41
CGWN 210	5.79	4.37	5.04	6.14	6.42
CGWN 211	5.90	4.35	5.17	6.25	6.55
CGWN 212	5.46	4.00	4.73	5.71	6.23
CGWN 213	5.53	3.97	4.90	5.69	6.34
CGWN 214	5.32	3.89	4.81	5.54	5.86
CGWN 215	5.41	4.05	4.90	5.59	6.01

EER: Energy Efficiency Ratio

Table 9 - European Seasonal Energy Efficiency Ratio (ESEER) - CGWN High Efficiency (HE)

Model	ESEER	A 100% load EER	B 75% load EER	C 50% load EER	D 25% load EER
CGWN 205 HE	6.39	4.82	5.66	6.74	7.02
CGWN 206 HE	6.36	4.75	5.51	6.74	7.11
CGWN 207 HE	6.39	4.71	5.62	6.78	7.00

EER: Energy Efficiency Ratio

General data

Table 10 - Water cooled units: CGWN standard – R410A

		CGWN 205	CGWN 206	CGWN 207	CGWN 208	CGWN 209	CGWN 210	CGWN 211
Eurovent Performances (1)								
Net Cooling Capacity	(kW)	182.5	217.0	251.7	283.1	312.1	341.9	373.7
Total Power input in cooling	(kW)	42.5	50.2	57.7	61.5	70.1	78.2	85.9
Evaporator water pressure drop	(kPa)	57	59	55	42	42	50	54
Evaporator head pressure available (4)	(kPa)	161	141	142	149	143	188	176
Condenser water pressure drop	(kPa)	59	64	60	47	52	63	65
Condenser head pressure available	(kPa)	151	134	138	162	150	132	117
Main Power supply		400/3/50						
Sound Power Level (4)	(dBA)	82	82	83	83	84	84	84
Sound Power Level (4) w/ sound attenuation jacket	(dBA)	79	79	80	80	81	81	81
Units Amps								
Nominal (3)	(A)	144	163	187	210	233	250	263
Start-up Amps								
Standard unit	(A)	274	338	395	418	441	512	525
With soft starter option	(A)	210	252	291	314	337	384	397
Short circuit unit capacity	(kA)	15	15	15	15	15	15	15
Max supply cable size	(mm ²)	150	150	150	150	150	240	240
Min supply cable size	(mm ²)	35	35	50	50	70	70	70
Compressor								
Number		4						
Type		Scroll						
Model		(15T+15T)	(15T+20T)	(20T+20T)	(20T+25T)	(25T+25T)	(25T+30T)	(30T+30T)
Speeds number		1						
Motors Number		1						
Rated Amps (compA/CompB) (3)	(A)	31/31	31/40	40/40	40/52	52/52	52/58	58/58
Locked rotor Amps (compA/CompB)	(A)	160/160	160/215	215/215	215/260	260/260	260/320	320/320
Motor RPM	(rpm)	2900						
Power factor (compA/CompB)		0.82/0.82	0.82/0.87	0.87/0.87	0.87/0.84	0.84/0.84	0.84/0.88	0.88/0.88
Sump Heater (compA/CompB)	(W)	160/160						
Evaporator								
Number		1						
Type		Braze plate						
Model		DP400-74	DP400-90	DP400-114	DP400-162	DP400-186	DP400-186	DP400-206
Water volume (total)	(L)	15.6	18.9	24.0	34.1	39.2	39.2	43.4
Antifreeze Heater	(W)	-	-	-	-	-	-	-
Evaporator Water Connections		Grooved pipe connection						
Diameter		3"	3"	4"	4"	4"	4"	4"
Max. water-side operating pressure								
without hydraulic module	(kPa)	1000						
with hydraulic module	(kPa)	400						
Condenser								
Number		1						
Type		Braze plate						
Model		DP400-90	DP400-114	DP400-134	DP400-186	DP400-206	DP400-206	DP400-222
Water volume (total)	(L)	18.9	24.0	28.2	39.2	43.4	43.4	46.7
Antifreeze Heater	(W)	-	-	-	-	-	-	-
Condenser Water Connections		Grooved pipe connection						
Diameter		3 or 4"	3 or 4"	3 or 4"	4"	4"	4"	4"
Max. water-side operating pressure								
without hydraulic module	(kPa)	1000						
with hydraulic module suction/discharge	(kPa)	400/640						
Dimensions								
Height	(mm)	1842	1842	1842	1842	1842	1842	1842
Length	(mm)	2545	2545	2545	2545	2545	2545	2545
Width	(mm)	880	880	880	880	880	880	880
Operating Weight								
Base Unit	(kg)	1360	1300	1420	1500	1650	1710	1790
Evap Hyd Kit	(kg)	1450	1390	1590	1670	1820	1880	1960
Evap + Cds Hyd Kit	(kg)	1520	1460	1690	1770	1920	1980	2060
Shipping Weight								
Base Unit	(kg)	1290	1220	1320	1370	1510	1570	1650
Evap Hyd Kit	(kg)	1380	1310	1490	1540	1680	1740	1820
Evap + Cds Hyd Kit	(kg)	1450	1380	1590	1640	1780	1840	1920
System Data								
Refrigerant circuit		2						
Capacity steps		4						
Minimum capacity	%	25	21	25	22	25	23	25
Refrigerant Charge (2)								
Circuit 1 & 2	(kg)	10	11	13	17	18	18	19
Oil Charge (2)								
Circuit 1 & 2	(l)	13.4	13.4	13.4	13.4	13.4	13.9	14.4

(1) at Eurovent Conditions (Evap 12°C/7°C - Condenser. 30°C/35°C)
(2) per circuit
(3) Max rated conditions.
(4) Dual Pump Option

General data

Table 11 - Water Cooled units: CGWN standard - R407C

		CGWN 212	CGWN 213	CGWN 214	CGWN 215
Eurovent Performances (1)					
Net Cooling Capacity	(kW)	398.6	431.3	466.0	506.4
Total Power input in cooling	(kW)	970	106.4	117.3	125.5
Evaporator water pressure drop	(kPa)	40	47	49	48
Evaporator head pressure available (4)	(kPa)	236	218	200	187
Condenser water pressure drop	(kPa)	66	64	59	56
Condenser head pressure available	(kPa)	159	151	147	136
Main Power supply				400/3/50	
Sound Power Level (4)	(dBA)	87	88	88	90
Sound Power Level w/ sound attenuation jacket (4)	(dBA)	84	85	85	87
Units Amps					
Nominal (3)	(A)	311	337	370	400
Start-up Amps					
Standard unit	(A)	563	588	621	655
With soft starter option	(A)	439	465	498	530
Short circuit unit capacity	(kA)	15	15	15	15
Max supply cable size	(mm ²)	185	185	240	240
Min supply cable size	(mm ²)	240	240	240	240
Compressor					
Number		5	6	6	6
Type				Scroll	
Model		(25T+30T)	(25T)	(25T+30T)	(30T)
Speeds number				1	
Motors Number				1	
Rated Amps (compA/CompB) (3)	(A)	52/62.5	52/52	52/62.5	62.5/62.5
Locked rotor Amps (compA/CompB)	(A)	272/310	272/272	272/310	310/310
Motor RPM	(rpm)	2900	2900	2900	2900
Power factor (compA/CompB)		0.87/0.87	0.87/0.87	0.87/0.87	0.87/0.87
Sump Heater (compA/CompB)	(W)	150	150	150	150
Evaporator					
Number				1	
Type				Brazed plate	
Model		AC350-190DQ	AC350-190DQ	AC350-210DQ	AC350-230DQ
Water volume (total)	(L)	38	38	42	46
Antifreeze Heater	(W)	-	-	-	-
Evaporator Water Connections				Grooved pipe connections	
Diameter				4"	
Max. water-side operating pressure,					
without hydraulic module	(kPa)	1000	1000	1000	1000
with hydraulic module	(kPa)	400	400	400	400
Condenser					
Number				2	
Type				Brazed plate	
Model		B400T- 94p / 114p	B400T- 114p / 114p	B400T- 114p / 144p	B400T- 144p / 144p
Water volume (total)	(L)	19 / 23	23 / 23	23 / 29	29 / 29
Antifreeze Heater	(W)	-	-	-	-
Condenser Water Connections				Grooved pipe connections	
Diameter				5"	
Max. water-side operating pressure,					
without hydraulic module	(kPa)	1000	1000	1000	1000
with hydraulic module	(kPa)	400	400	400	400
Dimensions without Hydraulic Module					
Height	(mm)	1950	1950	1950	1950
Length	(mm)	2808	2808	2808	2808
Width	(mm)	878	878	878	878
Dimensions with Hydraulic Module					
Height	(mm)	1950	1950	1950	1950
Length	(mm)	3498	3498	3498	3498
Width	(mm)	878	878	878	878
Operating Weight					
Base Unit w/o Hyd Kit	(kg)	2232	2442	2525	2640
Base Unit with Hyd Kit	(kg)	2128	2337	2420	2500
Evap Hyd Kit	(kg)	490	490	490	490
Cds Hyd Kit	(kg)	374	374	374	374
Evap + Cds Hyd Kit	(kg)	682	682	682	682
Shipping Weight					
Base Unit w/o Hyd Kit	(kg)	2109	2315	2387	2492
Base Unit with Hyd Kit	(kg)	2048	2253	2326	2408
Evap Hyd Kit	(kg)	432	432	432	432
Cds Hyd Kit	(kg)	317	317	317	317
Evap + Cds Hyd Kit	(kg)	662	662	662	662
System Data					
Number of Refrigerant circuit				2	
Capacity steps		5	6	6	6
Minimum capacity	%	18	16	15	16
Refrigerant Charge (2)					
Circuit A & B	(kg)	22 / 21	22 / 22	25 / 23	26 / 26
Oil Charge (2)					
Circuit A & B	(l)	20.4 / 12.6	20.4 / 20.4	18.9 / 20.4	18.9 / 18.9

 (1) at Eurovent Conditions (Evap 12°C/7°C - Condenser 30°C/35°C)
 (2) per circuit

 (3) Max rated conditions.
 (4) Dual Pump Option

General data

Table 12 - Water Cooled units: CGWN High Efficiency (HE) - R410A

		CGWN 205 HE	CGWN 206 HE	CGWN 207 HE
Eurovent Performances (1)				
Net Cooling Capacity	(kW)	193.3	227.4	262.4
Total Power input in cooling	(kW)	40.1	47.9	55.7
Evaporator water pressure drop	(kPa)	26	36	37
Evaporator head pressure available (4)	(kPa)	188	156	160
Condenser water pressure drop	(kPa)	31	42	41
Condenser head pressure available	(kPa)	177	154	173
Main Power supply				
Sound Power Level (4)	(dBA)	82	82	83
Sound Power Level w/ sound attenuation jacket (4)	(dBA)	79	79	80
Units Amps				
Nominal (3)	(A)	144	163	187
Start-up Amps				
Standard unit	(A)	274	338	395
With soft starter option	(A)	210	252	291
Short circuit unit capacity	(kA)	15	15	15
Max supply cable size	(mm ²)	150	150	150
Min supply cable size	(mm ²)	35	35	50
Compressor				
Number			4	
Type			Scroll	
Model		(15T+15T)	(15T+20T)	(20T+20T)
Speeds number			1	
Motors Number			1	
Rated Amps (compA/CompB) (3)	(A)	31/31	31/40	40/40
Locked rotor Amps (compA/CompB)	(A)	160/160	160/215	215/215
Motor RPM	(rpm)	2900	2900	2900
Power factor (compA/CompB)		0.82/0.82	0.82/0.87	0.87/0.87
Sump Heater (compA/CompB)	(W)	160/160	160/160	160/160
Evaporator				
Number			1	
Type			Brazed plate	
Model		DV58-138	DV58-154	DV58-170
Water volume (total)	(l)	32.4	32.4	34.1
Antifreeze Heater	(W)		-	
Evaporator Water Connections			Grooved pipe connections	
Diameter		3" (80)	3" (80)	4" (100)
Max. water-side operating pressure.				
without hydraulic module	(kPa)	1000	1000	1000
with hydraulic module	(kPa)	400	400	400
Condenser				
Number				
Type			Brazed plate	
Model		DP400-162	DP400-162	DP400-186
Water volume (total)	(l)	34.1	34.1	39.2
Antifreeze Heater	(W)		-	
Condenser Water Connections			Grooved pipe connection	
Diameter			3" (80)	
Antifreeze heater	(W)		-	
Max. water-side operating pressure				
without hydraulic module	(kPa)	1000	1000	1000
with hydraulic module suction/discharge	(kPa)	400/640	400/640	400/640
Dimensions				
Height	(mm)		1842	
Length	(mm)		2545	
Width	(mm)		880	
Operating Weight				
Base Unit	(kg)	1460	1450	1470
Evap Hyd Kit	(kg)	1550	1540	1640
Evap + Cds Hyd Kit	(kg)	1620	1610	1740
Shipping Weight				
Base Unit	(kg)	1360	1350	1340
Evap Hyd Kit	(kg)	1450	1440	1510
Evap + Cds Hyd Kit	(kg)	1520	1510	1610
System Data				
Refrigerant circuit			2	
Capacity steps		4	4	4
Minimum capacity	%	25	21	25
Refrigerant Charge (2)				
Circuit A & B	(kg)	15	15	17
Oil Charge (2)				
Circuit A & B	(l)	13.4	13.4	13.4

(1) at Eurovent Conditions (Evap 12°C/7°C - Condenser. 30°C/35°C)

(2) per circuit

(3) Max rated conditions.

(4) Dual Pump Option

General data

Table 13 - Condenserless units: CCUN standard - R410A

		CCUN 205	CCUN 206	CCUN 207	CCUN 208	CCUN 209	CCUN 210	CCUN 211
Eurovent Performances (1)								
Net Cooling Capacity	(kW)	166.3	198.1	230.4	257.7	281.9	311.4	343.8
Total Power input in cooling	(kW)	45.6	53.8	62.0	69.8	77.7	86.4	95.1
Evaporator water pressure drop	(kPa)	48	49	47	35	34	41	46
Evaporator head pressure available (4)	(kPa)	178	161	153	160	157	200	189
Main Power supply					400/3/50			
Sound Power Level (4)	(dBA)	82	82	83	83	84	84	84
Sound Power Level (4) w/ sound attenuation jacket	(dBA)	79	79	80	80	81	81	81
Units Amps								
Nominal (3)	(A)	132	151	172	195	218	236	249
Start-up Amps								
Standard unit	(A)	262	326	381	404	427	498	511
With soft starter option	(A)	198	240	277	300	323	370	383
Short circuit unit capacity	(kA)	15	15	15	15	15	15	15
Max supply cable size	(mm ²)	150	150	150	150	150	240	240
Min supply cable size	(mm ²)	35	35	50	50	70	70	70
Compressor								
Number					4			
Type					Scroll			
Model		(15T+15T)	(15T+20T)	(20T+20T)	(20T+25T)	(25T+25T)	(25T+30T)	(30T+30T)
Speeds number					1			
Motors Number					1			
Rated Amps (compA/CompB)	(A)	31/31	31/40	40/40	40/52	52/52	52/58	58/58
Locked rotor Amps (compA/CompB)	(A)	160/160	160/215	215/215	215/260	260/260	260/320	320/320
Motor RPM	(rpm)				2900			
Power factor (compA/CompB)		0.82/0.82	0.82/0.87	0.87/0.87	0.87/0.84	0.84/0.84	0.84/0.88	0.88/0.88
Sump Heater (compA/CompB)	(W)				160/160			
Evaporator								
Number					1			
Type					Brazed plate			
Model		DP400-74	DP400-90	DP400-114	DP400-162	DP400-186	DP400-186	DP400-206
Water volume (total)	(L)	15.6	18.9	24.0	34.1	39.2	39.2	43.4
Antifreeze Heater	(W)	-	-	-	-	-	-	-
Evaporator Water Connections					Grooved pipe connections			
Diameter		3"	3"	4"	4"	4"	4"	4"
Max. water-side operating pressure								
without hydraulic module	(kPa)				1000			
with hydraulic module	(kPa)				400			
Remote condenser connections								
Discharge line diameter circuit 1 & 2		1 3/8	1 3/8	1 3/8	1 5/8	1 5/8	1 5/8	1 5/8
Liquid line diameter circuit 1 & 2		7/8	7/8	7/8	7/8	7/8	1 1/8	1 1/8
Dimensions								
Height	(mm)	1842	1842	1842	1842	1842	1842	1842
Length	(mm)	2545	2545	2545	2545	2545	2545	2545
Width	(mm)	880	880	880	880	880	880	880
Operating Weight								
Base Unit	(kg)	1260	1170	1270	1280	1420	1480	1550
Evap Hyd Kit	(kg)	1350	1260	1440	1450	1590	1650	1720
Shipping Weight								
Base Unit	(kg)	1210	1120	1200	1190	1320	1380	1450
Evap Hyd Kit	(kg)	1300	1210	1370	1360	1490	1550	1620
System Data								
Refrigerant circuit					2			
Capacity steps		4	4	4	4	4	4	4
Minimum capacity	%	25	21	25	22	25	23	25
Refrigerant Charge (2)								
Circuit 1 & 2	(kg)	3	3	3	3	3	3	3
Oil Charge (2)								
Circuit 1 & 2	(l)	13.4	13.4	13.4	13.4	13.4	13.9	14.4

(1) Conditions (Evap 12°C/7°C - Saturated discharge 45°C - 5°C subcooling)

(2) per circuit

(3) Max rated conditions.

(4) Dual Pump Option

General data

Table 14 - Condenserless units: CCUN standard - R407C

		CCUN 212	CCUN 213	CCUN 214	CCUN 215
Eurovent Performances (1)					
Net Cooling Capacity	(kW)	385.6	4173	450.4	486.9
Total Power input in cooling	(kW)	99.0	108.5	120.5	131.1
Evaporator water pressure drop	(kPa)	38	44	46	45
Evaporator head pressure available (4)	(kPa)	242	227	211	197
Main Power supply		400/3/50			
Sound Power Level (4)	(dBA)	87	88	88	90
Sound Power Level w/ sound attenuation jacket (4)	(dBA)	84	85	85	87
Units Amps					
Nominal (3)	(A)	280	306	339	369
Start-up Amps					
Standard unit	(A)	532	557	590	624
With soft starter option	(A)	408	434	467	499
Short circuit unit capacity	(kA)	15	15	15	15
Max supply cable size	(mm ²)	185	185	240	240
Min supply cable size	(mm ²)	240	240	240	240
Compressor					
Number		5	6	6	6
Type		Scroll			
Model		(25T+30T)	(25T)	(25T+30T)	(30T)
Speeds number		1			
Motors Number		1			
Rated Amps (compA/CompB) (3)	(A)	52/62.5	52/52	52/62.5	62.5/62.5
Locked rotor Amps (compA/CompB)	(A)	272/310	272/272	272/310	310/310
Motor RPM	(rpm)	2900	2900	2900	2900
Power factor (compA/CompB)		0.87/0.87	0.87/0.87	0.87/0.87	0.87/0.87
Sump Heater (compA/CompB)	(W)	150	150	150	150
Evaporator					
Number		1			
Type		Braze plate			
Model		AC350-190DQ	AC350-190DQ	AC350-210DQ	AC350-230DQ
Water volume (total)	(l)	38	38	42	46
Antifreeze Heater	(W)	no	no	no	no
Evaporator Water Connections		Grooved pipe connections			
Diameter		4"			
Max. water-side operating pressure,					
without hydraulic module	(kPa)	1000	1000	1000	1000
with hydraulic module	(kPa)	400	400	400	400
Remote condenser connections					
Discharge line diameter circuit 1 & 2		2"1/8	2"1/8	2"1/8	2"1/8
Liquid line diameter circuit 1 & 2		1"3/8	1"3/8	1"3/8	1"3/8
Dimensions without Hydraulic Module					
Height	(mm)	1950	1950	1950	1950
Length	(mm)	2808	2808	2808	2808
Width	(mm)	878	878	878	878
Dimensions with Hydraulic Module					
Height	(mm)	1950	1950	1950	1950
Length	(mm)	3498	3498	3498	3498
Width	(mm)	878	878	878	878
Operating Weight					
Base Unit w/o Hyd Kit	(kg)	1879	2070	2120	2180
Base Unit with Hyd Kit	(kg)	1880	2071	2122	2182
Evap Hyd Kit	(kg)	490	490	490	490
Shipping Weight					
Base Unit w/o Hyd Kit	(kg)	1832	2023	2070	2130
Base Unit with Hyd Kit	(kg)	1842	2033	2080	2136
Evap Hyd Kit	(kg)	432	432	432	432
System Data					
Refrigerant circuit		2			
Capacity steps		4	4	4	4
Minimum capacity	%	22	33	30	33
Refrigerant Charge (2)					
Circuit A & B	(kg)	Holding charge			
Oil Charge (2)					
Circuit A & B	(l)	20.4 / 12.6	20.4 / 20.4	18.9 / 20.4	18.9 / 18.9

(1) Conditions (Evap 12°C/7°C - Saturated discharge 45°C - 5°C subcooling)
(2) per circuit

(3) Max rated conditions.
(4) Dual Pump Option

General data

Table 15 - Condenserless units: CCUN High Efficiency (HE) - R410A

		CCUN 205 HE	CCUN 206 HE	CCUN 207 HE
Eurovent Performances (1)				
Net Cooling Capacity	(kW)	175.0	206.7	239.1
Total Power input in cooling	(kW)	45.6	53.8	62.0
Evaporator water pressure drop	(kPa)	22	29	30
Evaporator head pressure available (4)	(kPa)	190	170	170
Main Power supply			400/3/50	
Sound Power Level (4)	(dBA)	82	82	83
Sound Power Level w/ sound attenuation jacket (4)	(dBA)	79	79	80
Units Amps				
Nominal (3)	(A)	132	151	172
Start-up Amps				
Standard unit	(A)	262	326	381
With soft starter option	(A)	198	240	277
Short circuit unit capacity	(kA)	15	15	15
Max supply cable size	(mm ²)	150	150	150
Min supply cable size	(mm ²)	35	35	50
Compressor				
Number			4	
Type			Scroll	
Model		(15T+15T)	(15T+20T)	(20T+20T)
Speeds number			1	
Motors Number			1	
Rated Amps (compA/CompB) (3)	(A)	31/31	31/40	40/40
Locked rotor Amps (compA/CompB)	(A)	160/160	160/215	215/215
Motor RPM	(rpm)	2900	2900	2900
Power factor (compA/CompB)		0.82/0.82	0.82/0.87	0.87/0.87
Sump Heater(compA/CompB)	(W)	160/160	160/160	160/160
Evaporator				
Number			1	
Type			Brazed plate	
Model		DP400-154	DP400-154	DP400-162
Water volume (total)	(L)	32.4	32.4	34.1
Antifreeze Heater	(W)		-	
Evaporator Water Connections			Grooved pipe connections	
Diameter			3"	
Max. water-side operating pressure				
without hydraulic module	(kPa)	1000	1000	1000
with hydraulic module	(kPa)	400	400	400
Remote condenser connections				
Discharge line diameter circuit 1 & 2			1 3/8	
Liquid line diameter circuit 1 & 2		7/8	7/8	7/8
Dimensions				
Height	(mm)		1842	
Length	(mm)		2545	
Width	(mm)		880	
Operating Weight				
Base Unit	(kg)	1330	1240	1250
Evap Hyd Kit	(kg)	1420	1330	1420
Shipping Weight				
Base Unit	(kg)	1270	1170	1160
Evap Hyd Kit	(kg)	1360	1260	1330
System Data				
Refrigerant circuit			2	
Capacity steps			4	
Minimum capacity	%	25	21	25
Refrigerant Charge (2)				
Circuit 1 & 2	(kg)		Holding charge	
Oil Charge (2)				
Circuit 1 & 2	(l)	13.4	13.4	13.4

(1) Conditions (Evap 12°C/7°C - Saturated discharge 45°C - 5°C subcooling)
 (2) per circuit

(3) Max rated conditions.
 (4) Dual Pump Option

General data

Table 16 - Evaporator hydraulic module

		205	206	207	208	209	210	211	212	213	214	215
High head pressure option												
Nb Pump set							1					
Motor (1)(2)	(kW)	4.0	4.0	5.5	5.5	5.5	7.5	7.5	11.0	11.0	11.0	11.0
Rated Amps (1)(2)	(A)	7.5	7.5	11.1	11.1	11.1	14.7	14.7	20.0	20.0	20.0	20.0
Motor RPM	(rpm)						2900					
Low head pressure option												
Nb Pump set							1					
Motor (1)(2)	(kW)	2.2	2.2	4.0	4.0	4.0	5.5	5.5	4.0	4.0	5.5	5.5
Rated Amps (1)(2)	(A)	4.0	4.0	7.5	7.5	7.5	11.1	11.1	7.8	7.8	10.3	10.3
Motor RPM	(rpm)						2900					
Expansion tank volume	(l)	25	25	25	25	25	25	25	35	35	35	35
User volume expansion capacity (3)	(l)	3600	3600	3600	3600	3600	3600	3600	5100	5100	5100	5100
Water strainer diameter		3"	3"	4"	4"	4"	4"	4"	4"	4"	4"	4"
Piping							Steel					

Table 17 - Condenser hydraulic module

		205	206	207	208	209	210	211	212	213	214	215
High head pressure option												
Nb Pump set							2 (in parallel)					
Motor (1)(2)	(kW)	3	3	4	4	4	4	4	7.5	7.5	7.5	7.5
Rated Amps (1)(2)	(A)	6.1	6.1	7.7	7.7	7.7	7.7	7.7	13.8	13.8	13.8	13.8
Motor RPM	(rpm)						2900					
Low head pressure option												
Nb Pump set							2 (in parallel)					
Motor (1)(2)	(kW)	2.2	2.2	3.0	3.0	3.0	3.0	3.0	4.0	4.0	5.5	5.5
Rated Amps (1)(2)	(A)	4.2	4.2	6.1	6.1	6.1	6.1	6.1	7.8	7.8	10.3	10.3
Motor RPM	(rpm)						2900					
Water strainer diameter		4"	4"	4"	4"	4"	4"	4"	4"	4"	4"	4"
Piping							Steel					

(1) per motor

(2) Dual Pump Option

(3) Hydrostatic pressure 3 bar at 25°C with 7°C mini

Hydraulic data

Figure 8 - Standard and High Efficiency units evaporator pressure drop (205-215)

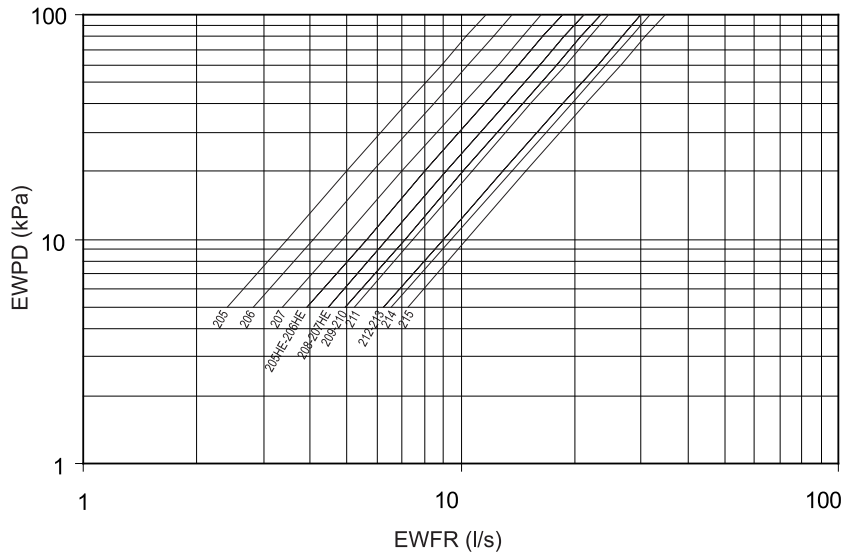

EWFR: Evaporator Waterflow Rate
EWPD: Evaporator Water Pressure Drop

Figure 9 - Standard and High Efficiency units condenser pressure drop

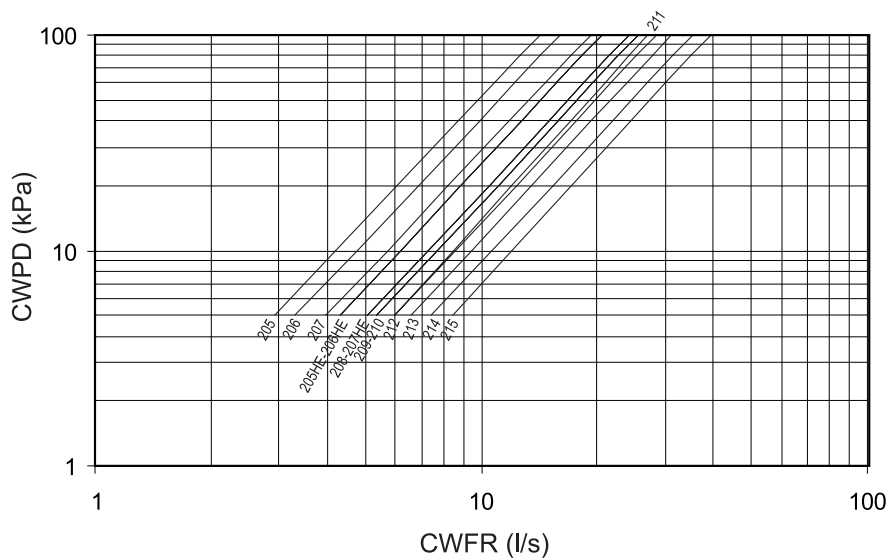

CWFR: Condenser Waterflow Rate
CWPD: Condenser Water Pressure Drop

Hydraulic data

Figure 10 - Evaporator available pressure - Standard and High Efficiency units – Low head pressure – Single pump

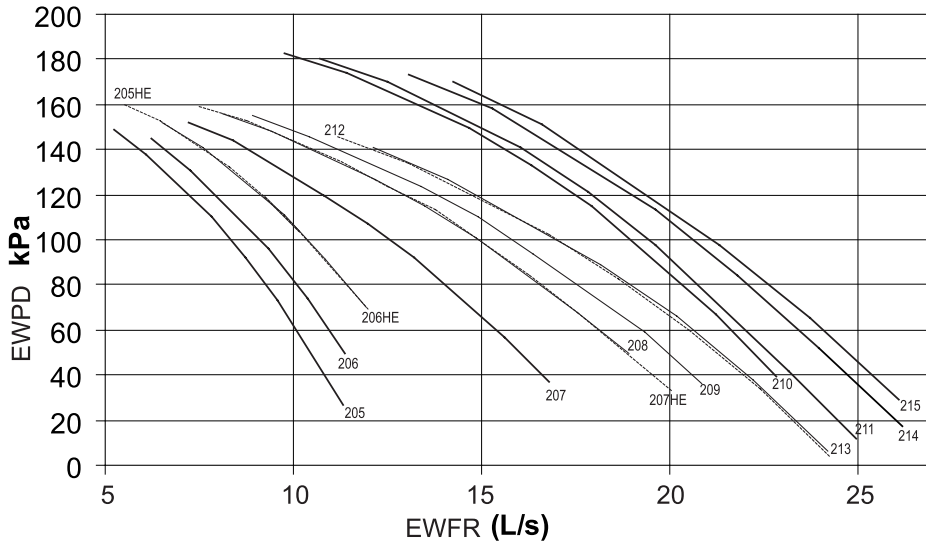

EWFR: Evaporator Waterflow Rate
EWPD: Evaporator Water Pressure Drop

Figure 11 - Evaporator available pressure - Standard and High Efficiency units – Low head pressure – Dual pump

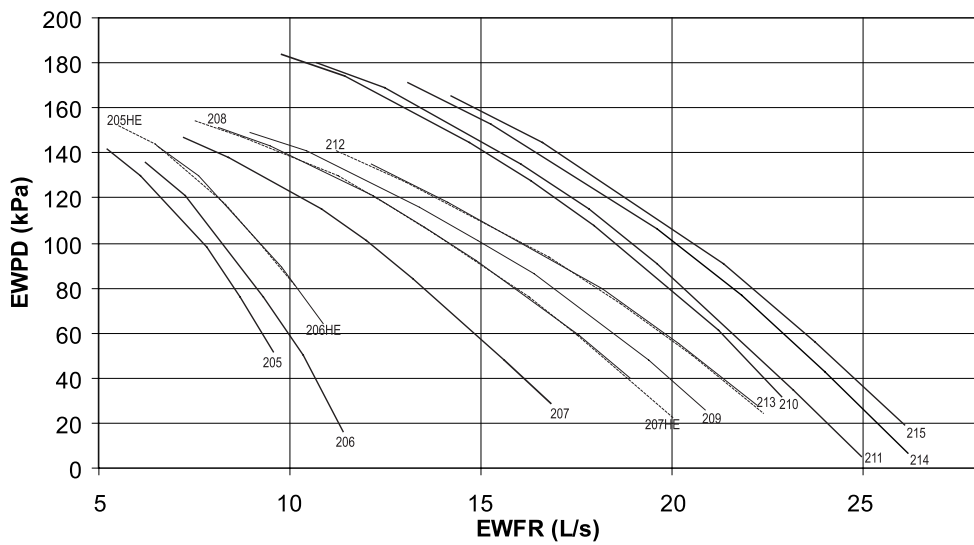

EWFR: Evaporator Waterflow Rate
EWPD: Evaporator Water Pressure Drop

Hydraulic data

Figure 12 - Evaporator available pressure - Standard and High Efficiency units - High head pressure - Single pump (205-211)

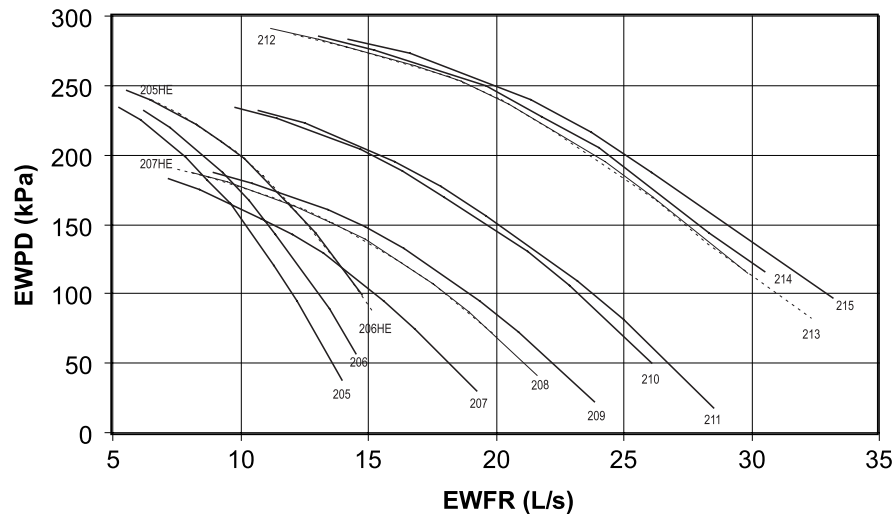

EWFR: Evaporator Waterflow Rate
 EWPD: Evaporator Water Pressure Drop

Figure 13 - Evaporator available pressure - Standard and High Efficiency units - High head pressure - Dual pump

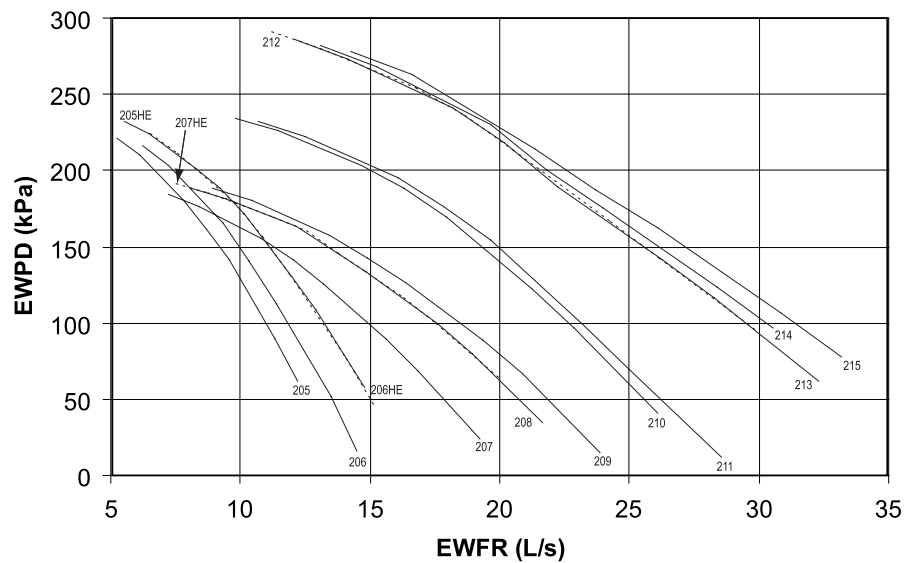

EWFR: Evaporator Waterflow Rate
 EWPD: Evaporator Water Pressure Drop

Hydraulic data

Figure 14 - Condenser available pressure - Standard and High Efficiency units – Low head pressure

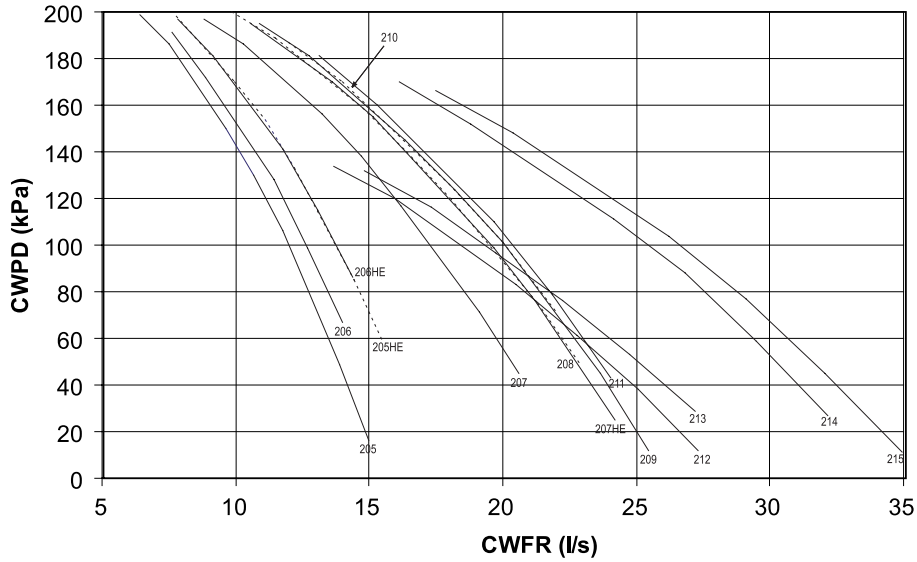

CWFR: Condenser Waterflow Rate
CWPD: Condenser Water Pressure Drop

Figure 15 - Condenser available pressure - Standard and High Efficiency units – High head pressure (205-211)

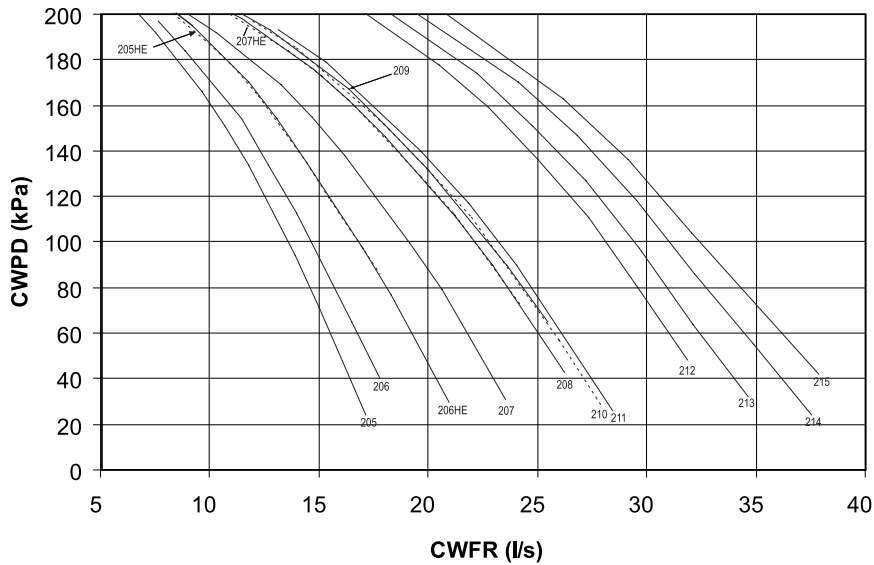

CWFR: Condenser Waterflow Rate
CWPD: Condenser Water Pressure Drop

Sound performances

Table 18 - Sound Power Level - standard and high efficiency units without compressor sound jacket

Size	Sound Power Level Lw (d(B))								Global dB(A)
	63 Hz	125 Hz	250 Hz	500 Hz	1 kHz	2 kHz	4 kHz	8 kHz	
205	93 dB	75 dB	76 dB	84 dB	71 dB	69 dB	65 dB	64 dB	82 dBA
206	92 dB	75 dB	76 dB	82 dB	75 dB	71 dB	67 dB	65 dB	82 dBA
207	92 dB	75 dB	76 dB	84 dB	76 dB	73 dB	68 dB	64 dB	83 dBA
208	91 dB	73 dB	76 dB	83 dB	78 dB	74 dB	69 dB	65 dB	83 dBA
209	91 dB	74 dB	77 dB	84 dB	79 dB	75 dB	70 dB	65 dB	84 dBA
210	91 dB	80 dB	81 dB	84 dB	78 dB	73 dB	67 dB	61 dB	84 dBA
211	91 dB	80 dB	80 dB	84 dB	80 dB	74 dB	69 dB	64 dB	84 dBA
212	94 dB	84 dB	89 dB	84 dB	79 dB	80 dB	71 dB	64 dB	87 dBA
213	95 dB	87 dB	88 dB	85 dB	81 dB	81 dB	73 dB	66 dB	88 dBA
214	84 dB	87 dB	88 dB	84 dB	83 dB	81 dB	74 dB	67 dB	88 dBA
215	95 dB	89 dB	88 dB	86 dB	85 dB	83 dB	76 dB	69 dB	90 dBA

* High efficiency not available for sizes 212 to 215

Table 19 - Sound Power Level - standard and high efficiency units with compressor sound jacket

Size	Sound Power Level Lw (d(B))								Global dB(A)
	63 Hz	125 Hz	250 Hz	500 Hz	1 kHz	2 kHz	4 kHz	8 kHz	
205	92 dB	74 dB	75 dB	81 dB	67 dB	62 dB	60 dB	55 dB	79 dBA
206	91 dB	74 dB	74 dB	80 dB	71 dB	65 dB	61 dB	56 dB	79 dBA
207	91 dB	74 dB	76 dB	82 dB	72 dB	66 dB	63 dB	56 dB	80 dBA
208	90 dB	73 dB	75 dB	81 dB	74 dB	68 dB	64 dB	57 dB	80 dBA
209	90 dB	73 dB	76 dB	81 dB	74 dB	69 dB	64 dB	57 dB	81 dBA
210	93 dB	79 dB	80 dB	82 dB	75 dB	67 dB	64 dB	58 dB	81 dBA
211	93 dB	79 dB	79 dB	81 dB	76 dB	69 dB	64 dB	62 dB	81 dBA
212	91 dB	85 dB	89 dB	83 dB	74 dB	75 dB	66 dB	55 dB	84 dBA
213	91 dB	85 dB	89 dB	83 dB	77 dB	77 dB	68 dB	57 dB	85 dBA
214	91 dB	85 dB	88 dB	83 dB	77 dB	78 dB	70 dB	59 dB	85 dBA
215	92 dB	87 dB	88 dB	84 dB	81 dB	78 dB	71 dB	60 dB	87 dBA

* High efficiency not available for sizes 212 to 215

The sound power levels above are valid for:

- CGWN water cooled chillers operating at a condenser leaving water temperature below or equal to 40°C
- CCUN condenserless chillers operating at a saturated condensing temperature below or equal to 45°C

Should the units operate at different conditions, apply correction factors to global sound pressure as described in the table below.

Table 20 - Correction factors for other conditions

		Without compressor sound jacket	With compressor sound jacket
CGWN	Condenser leaving water temperature	40 to 50 °C	+ 1 dB(A)
		50 to 58°C	+ 2 dB(A)
CCUN	Saturated condensing temperature	45 to 55°C	+ 1 dB(A)
		55 to 63°C	+ 2 dB(A)

Sound performances

Figure 16 - CGWN refrigerant flow chart (205-211)

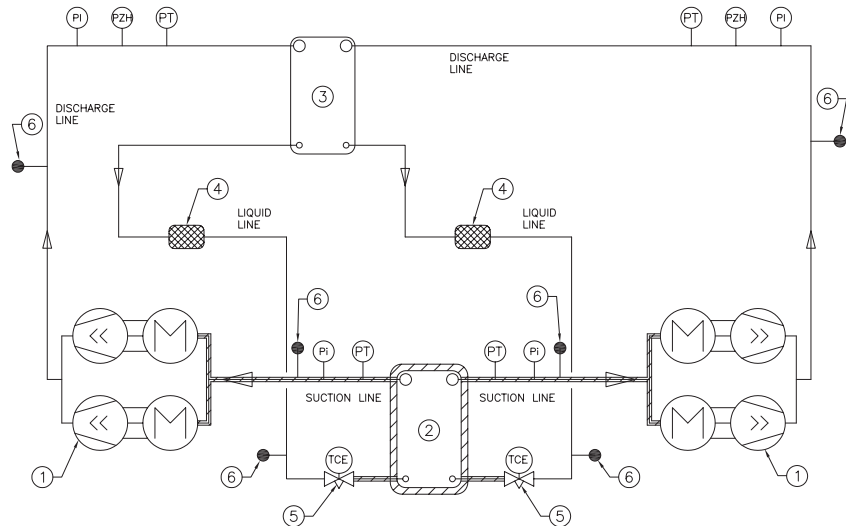
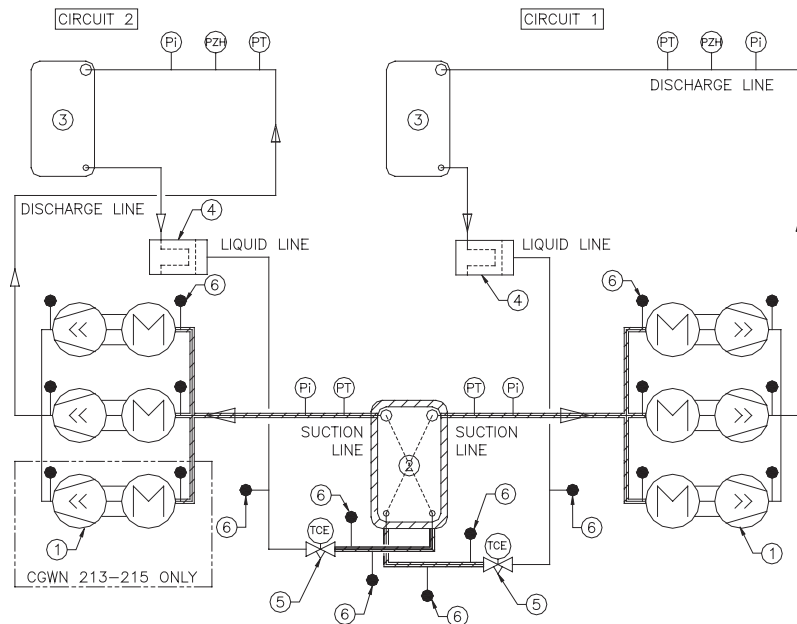

Figure 17 - CGWN refrigerant flow chart (212-215)



- 1: Scroll compressor
- 2: Brazed plate evaporator
- 3: Brazed plate condenser
- 4: Filter drier
- 5: Expansion valve
- 6: ¼ SAE Male pressure tab

- 7: Discharge line
- 8: Liquid Line
- 9: Suction Line
- Pi: Gauge
- PT: Pressure transducer
- PZH: High pressure switch

Units schematics

Figure 18 - CCUN refrigerant flow chart (205-211)

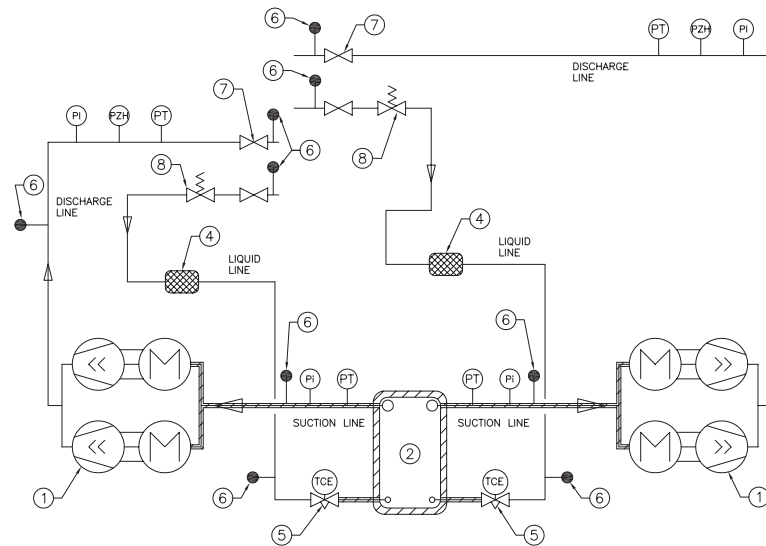
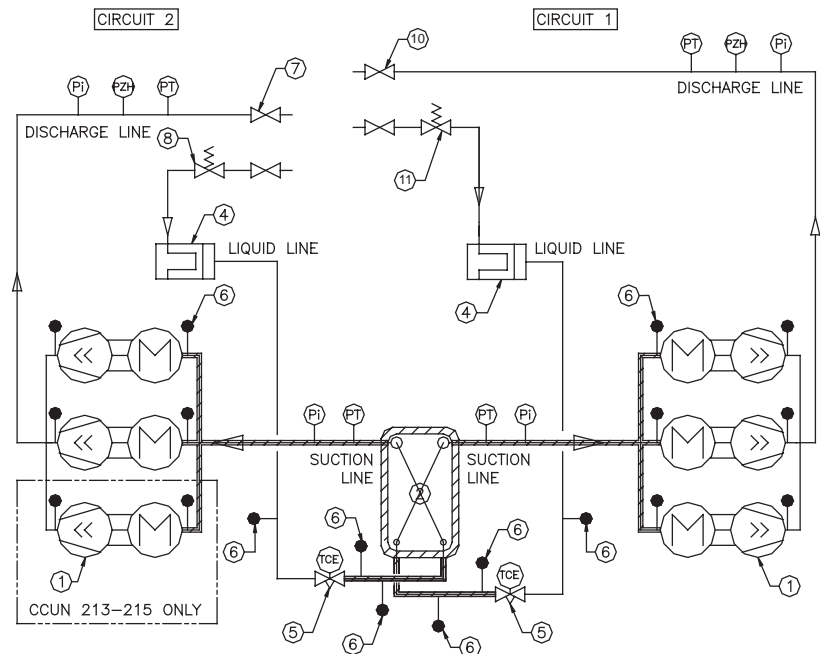

Figure 19 - CCUN refrigerant flow chart (212-215)



- 1: Scroll compressor
- 2: Brazed plate evaporator
- 4: Filter drier
- 5: Expansion valve
- 6: ¼ SAE Male pressure tab
- 7: Discharge line

- 8: Liquid Line
- 9: Suction Line
- 10: Service valve
- 11: Solenoid valve
- Pi: Gauge
- PT: Pressure transducer
- PZH: High pressure switch

Units schematics

Figure 20 - CGWN hydraulic flow chart – without hydraulic module (205-211)

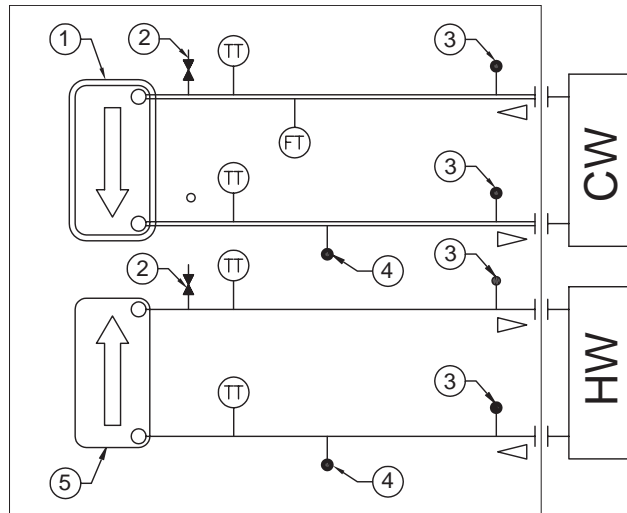
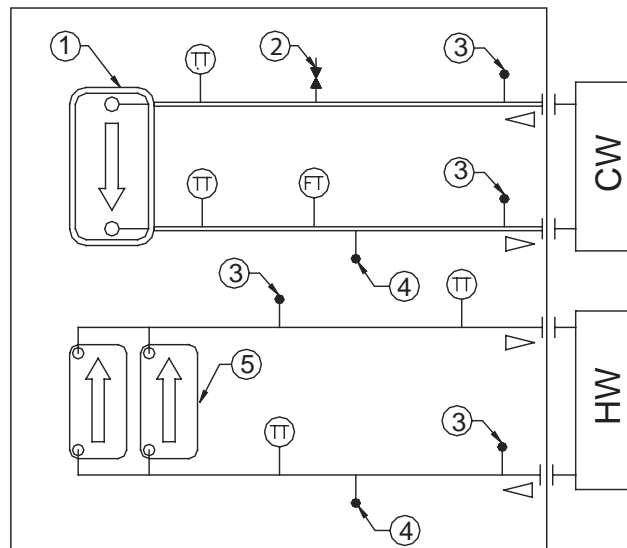

Figure 21 - CGWN hydraulic flow chart – without hydraulic module (212-215)



- 1: Insulated evaporator
- 2: Valve for air vent
- 3: ¼ SAE Male pressure tab
- 4: ¼ SAE Male drain tab
- 5: Condenser

- CW: Chilled water loop
- HW: Condensation water loop
- TT: Temperature sensor
- FT: Water flow switch

Units schematics

Figure 22 - CCUN hydraulic flow chart – without hydraulic module (205-211)

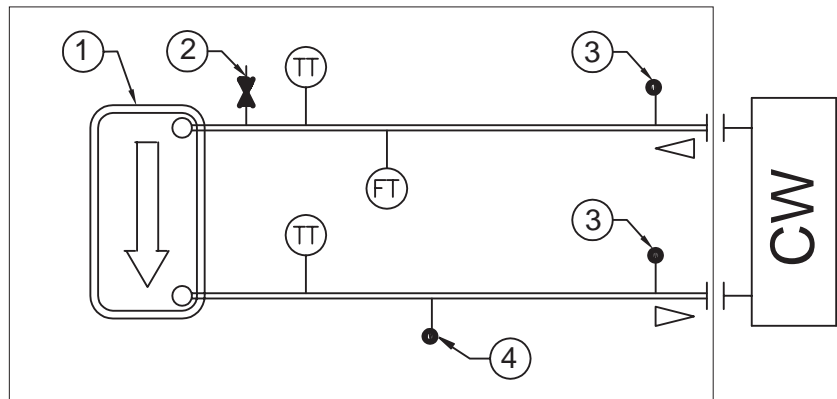
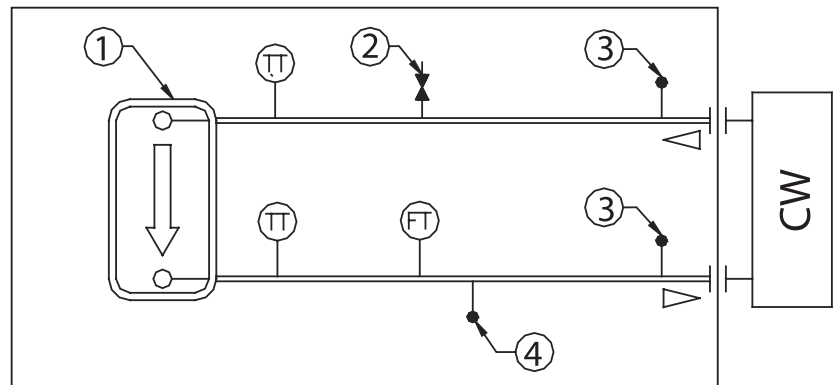

Figure 23 - CCUN hydraulic flow chart – without hydraulic module (212-215)



- 1: Insulated evaporator
- 2: Valve for air vent
- 3: ¼ SAE Male pressure tab
- 4: ¼ SAE Male drain tab
- 5: Condenser

- CW: Chilled water loop
- HW: Condensation water loop
- TT: Temperature sensor
- FT: Water flow switch

Units schematics

Figure 24 - CGWN hydraulic flow chart – with hydraulic module (205-211)

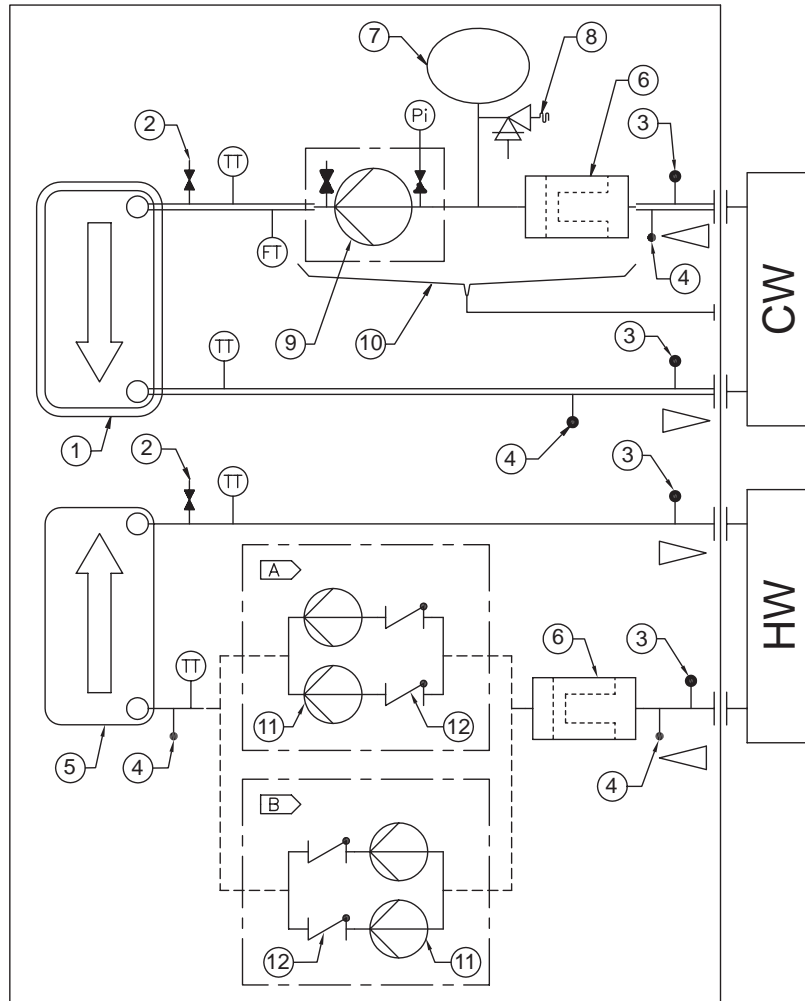

- | | |
|-------------------------------------|------------------------------------------|
| 1: Insulated evaporator | CW: Chilled water loop |
| 2: Valve for air vent | HW: Condensation water loop |
| 3: ¼ SAE Male pressure tab | TT: Temperature sensor |
| 4: ¼ SAE Male drain tab | Pi: Pressure gauge |
| 5: Condenser | FT: Water flow switch |
| 6: Water strainer | A: For sizes 205 to 207 standard head 3" |
| 7: Expansion Tank | B: For sizes 208 to 211 |
| 8: Pressure relief valve | and all sizes high 4" |
| 9: Single or double evaporator pump | |
| 10: Drain pan | |
| 11: Condenser pump | |
| 12: Check valve | |

Units schematics

Figure 25 - CGWN hydraulic flow chart – with hydraulic module (212-215)

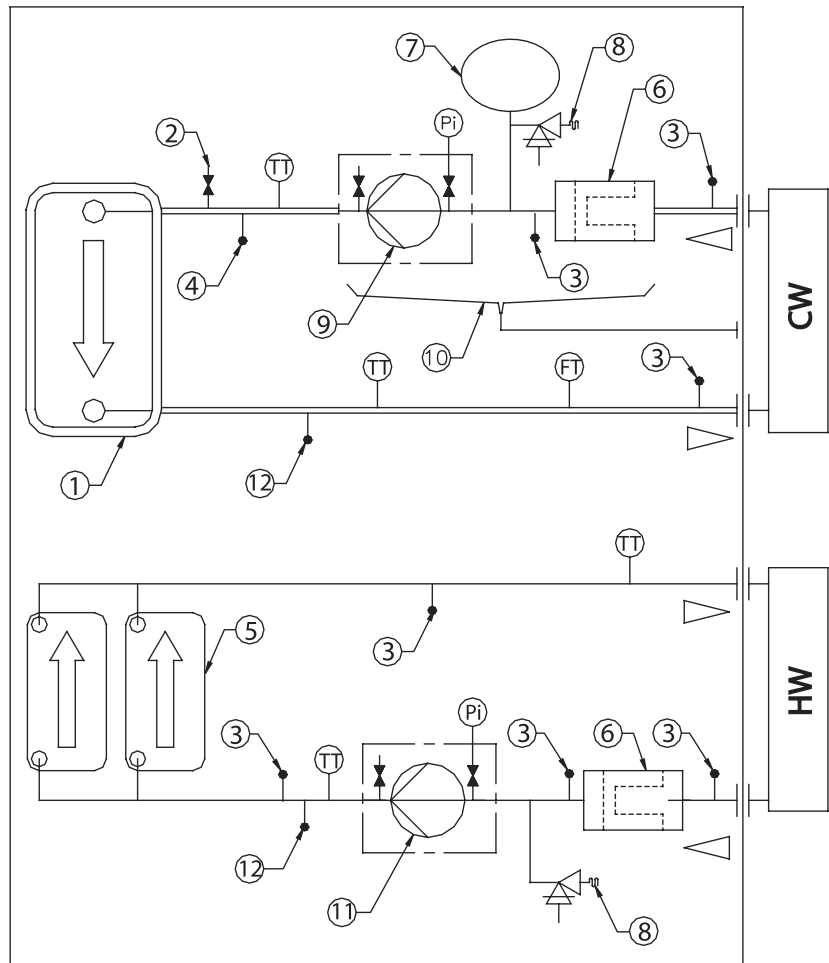

- 1: Insulated evaporator
- 2: Valve for air vent
- 3: ¼ SAE Male pressure tab
- 4: ¼ SAE Male drain tab
- 5: Condenser
- 6: Water strainer
- 7: Expansion Tank
- 8: Pressure relief valve
- 9: Single or double evaporator pump
- 10: Drain pan
- 11: Condenser pump
- 12: ¼ NPT drain tab

- CW: Chilled water loop
- HW: Condensation water loop
- TT: Temperature sensor
- Pi: Pressure gauge
- FT: Water flow switch

Units schematics

Figure 26 - CCUN hydraulic flow chart – with hydraulic module (205-211)

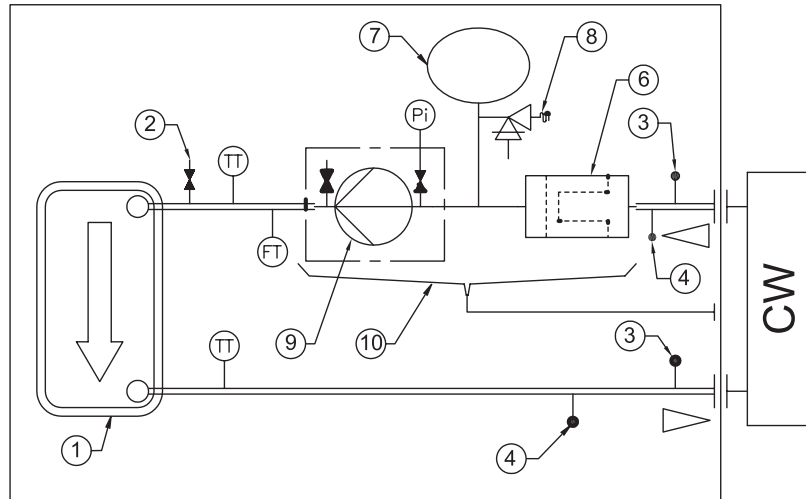
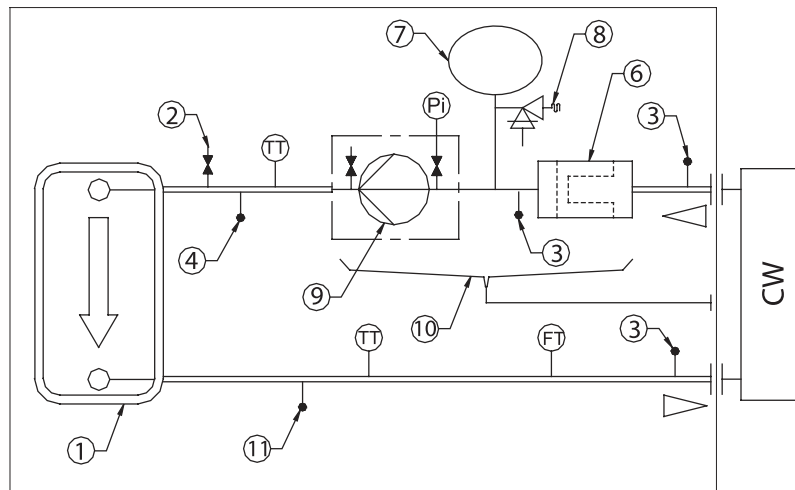

Figure 27 - CCUN hydraulic flow chart – with hydraulic module (212-215)



- | | |
|------------------------------|-------------------------------------|
| 1: Insulated evaporator | 8: Pressure relief valve |
| 2: Valve for air vent | 9: Single or double evaporator pump |
| 3: 1/4 SAE Male pressure tab | 10: Drain pan |
| 4: 1/4 SAE Male drain tab | 11: 1/4 NPT drain tab |
| 6: Water strainer | CW: Chilled water loop |
| 7: Expansion Tank | TT: Temperature sensor |
| | Pi: Pressure gauge |

Units schematics

Figure 28 - CGWN - CCUN units dimensions

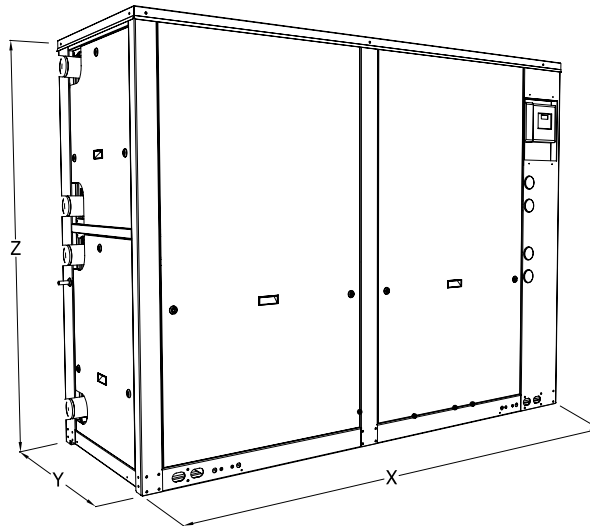

Table 21 - CGWN – CCUN dimensions

	Unit Dimensions		
	X mm	Y mm	Z mm
Unit with Hydraulic Module			
CGWN - CCUN 205			
CGWN - CCUN 206			
CGWN - CCUN 207			
CGWN - CCUN 208	2545	880	1842
CGWN - CCUN 209			
CGWN - CCUN 210			
CGWN - CCUN 211			
CGWN - CCUN 212			
CGWN - CCUN 213	3498	878	1950
CGWN - CCUN 214			
CGWN - CCUN 215			
Unit without Hydraulic Module			
CGWN - CCUN 205			
CGWN - CCUN 206			
CGWN - CCUN 207			
CGWN - CCUN 208	2545	880	1842
CGWN - CCUN 209			
CGWN - CCUN 210			
CGWN - CCUN 211			
CGWN - CCUN 212			
CGWN - CCUN 213	2808	878	1950
CGWN - CCUN 214			
CGWN - CCUN 215			

Mechanical Specifications

CGWN CCUN Indoor chiller

Indoor scroll compressor liquid chiller

- **CGWN:** packaged water cooled

- **CCUN:** Condenserless, for installation with a remote condenser

With following characteristics:

- operating with HFC-based refrigerant like R407C.
- furnished with scroll compressors, brazed plate evaporator, with microprocessor based control.
- comply with EC requirements for Machinery, Electromagnetic and Pressure Equipment Directives (98/37/CE directive), as amended, and with national implementing legislation.
- designed and manufactured in accordance with the quality assurance ISO 9001/BS EN ISO9001.
- certified and rated in accordance with Eurovent standard.
- designed for indoor application and painted.

2. Compressors

- Hermetic scroll compressors:
 - Direct-drive 2900 rpm
 - suction gas-cooled hermetic motor
 - built-in centrifugal oil pump

3. Evaporator

- Brazed plate heat exchanger, made of stainless steel and copper brazing.
- insulated with vinyl based closed cell insulation.

4. Condenser (CGWN only)

- 180-350 kW: One single brazed plate heat exchanger, made of stainless steel and copper brazing
- 350-500 kW: Two brazed plate heat exchanger in parallel made of stainless steel and copper brazing.

5. Unit construction

- Unit structure made of 2 mm steel profile, supporting casing and electrical panels made of galvanized steel 1 mm thick, entirely painted, integrating accessible and appropriate rigging points for an easy and safe handling at job site. The powder paint system (white color: RAL 9002) applied on the metal sheets of the casing withstand 500 hours in a salt-spray fog test minimum.
- Electrical panels fully mounted and wired in factory, with full opening access doors.

6. Refrigerant circuit

- All units have 2 refrigeration circuits, with:
 - 180-350 kW: Two (manifolded) compressors on each circuit
 - 350-500 kW: Three (manifolded) compressors on each circuit.

Note:

Size 212 has 2+3 manifolded compressor

- Provided for each refrigerant circuit:
 - High and Low pressure transducers.
 - Replaceable liquid filter-dryer.
 - Oil level sight glass and oil charging valve.
 - One thermostatic expansion valve per refrigerant circuit
 - Pressure port on each refrigerant line.
 - High pressure side dual pressure switch.

CGWN only: full operating charge of HFC-407C or R410A and P.O.E. oil.

CCUN only: holding charge of HFC-407C or R410A and operating charge P.O.E. oil. Liquid line solenoid valve, discharge and liquid line service valves.

7. Water side piping

- Field pipe connections Victaulic type provided at the outside of the unit casing.
- Electronic chilled water flow switch, factory installed.

Mechanical Specifications

Hydraulic module option:

- Fitted inside the chiller.

Evaporator side

- For:
 - 180-350 kW: Monocell centrifugal single or twin pump factory installed, twin pump system have pump discharge check valves
 - 350-500 kW: Twin pump with pump discharge check valves
- Pump crankcase of cast iron with closed type impeller, dynamically balanced.
- Pump rated for 1.2 MPa working pressure.
- Pre-charged expansion tank
- Water strainer to protect against particles with a diameter above 1.6 mm, "T" shape, cleanable by opening only one Victualic connection.
- Gauge tapings allow to measure evaporator pressure drop and available pressure drop.
- 400 kPa relief valve

Condenser side

- For:
 - 180-350 kW: 2 centrifugal simple pumps factory installed, operating in cascade to optimize energy consumption based on unit capacity. As an option, pumps with separate variable speed drives can be supplied.
 - 350-500 kW: Twin pump with pump discharge check valves
- Pump rated for 0.64 MPa working pressure. As an option, pumps with integrated variable speed drive can be supplied.
- Water strainer to protect against particles with a diameter above 1.6 mm, "T" shape, cleanable by opening only one Victualic connection.

8. Control panel

- Weatherproof control panel, containing starters, power and control wiring, mounted on the chiller, and include primary and secondary fused control power transformer with 2 secondary control circuits:
 - 230 volt single phase connection for evaporator freeze protection heaters and control circuit,
 - 24 volt single phase connection for electronic part of the control circuit.
- The power panel door locked by a main disconnect switch.

9. Unit Controls (CH530)

The microprocessor-based control panel is factory-installed and factory-tested. Chilled water reset based on return water is standard. The CH530 microprocessor automatically acts to prevent unit shutdown due to abnormal operating conditions associated with low evaporator refrigerant temperature, high condenser temperature, and/or motor current overload. If an abnormal operating condition continues and the protective limit is reached, the machine should shut down.

The panel includes machine protection shutdown requiring manual reset for the following conditions:

- low evaporator refrigerant temperature and pressure
- high condenser refrigerant pressure
- critical sensor or detection circuit faults
- motor current overload
- high compressor discharge temperature
- lost communication between main processor and LLID
- external and local emergency stop

Mechanical Specifications

The panel also includes machine protection shutdown with automatic reset for the following correctable conditions:

- power loss
- loss of evaporator or condenser water flow

When a fault is detected, the control system conducts more than 60 diagnostic checks and displays results.

The display will identify the fault, indicate date, time, and operating mode at time of occurrence, and provide type of reset required and a help message. The diagnostic history will display the last ten diagnostics with their times and dates of occurrence.

DynaView Panel

Factory-mounted to the control panel door, the operator interface has an LCD touch-screen display for operator input and information output. This interface provides access to the following information: evaporator report, condenser report, compressor report. All diagnostics and messages are displayed in "clear language."

Data contained in available reports includes:

- refrigerant pressure and temperatures
- flow switch status
- compressor starts and run-time

All necessary settings and set-points are programmed into the microprocessor based controller via the operator interface. The controller is capable of receiving signals contemporaneously from a variety of control sources, in any combination, and priority order of control sources can be programmed. The control source with priority determines active set-points via the signal it sends to the control panel.

Control sources may be:

- the local operator interface (standard)
- a 4-20 mA or 2-10 VDC signal from an external source (interface optional; control source not supplied)
- Trane Tracer Summit™ system (interface optional)
- LonTalk LCI-C (interface optional; control source not supplied)

Optional capabilities:

- water (CDS Inlet/Outlet) and air (outside ambient/zone) temperatures
- electrical distribution faults: current loss or phase reversal.

Notes

For additional information, contact :

The manufacturer has a policy of continuous product improvement, and reserves the right to alter any details of the products at any time without notice.

This publication is a general guide to install, use and properly maintain our products. The information given may be different from the specification for a particular country or for a specific order. In this event, please refer to your nearest office.

Distributor / Installer stamp



Quality Management
System Approval



TRANE®

Cooling and Heating
Systems and Services

Literature Order Number	CG-PRC014-E4
Date	1209
Supersedes	CG-PRC014-E4_0908

Trane has a policy of continuous product and product data improvement and reserves the right to change design and specifications without notice. Only qualified technicians should perform the installation and servicing of equipment referred to in this publication.

www.trane.com

For more information, contact your local sales office or e-mail us at comfort@trane.com

Trane bvba
Lenneke Marelaan 6 -1932 Sint-Stevens-Woluwe, Belgium
ON 0888.048.262 - RPR BRUSSELS